



CSA/ASC B652:23

National Standard of Canada



Accessible dwellings



Accessibility Standards
Canada

Normes d'accessibilité
Canada



Legal Notice for Standards

Canadian Standards Association (operating as “CSA Group”) develops standards through a consensus standards development process approved by the Standards Council of Canada. This process brings together volunteers representing varied viewpoints and interests to achieve consensus and develop a standard. Although CSA Group administers the process and establishes rules to promote fairness in achieving consensus, it does not independently test, evaluate, or verify the content of standards.

Disclaimer and exclusion of liability

This document is provided without any representations, warranties, or conditions of any kind, express or implied, including, without limitation, implied warranties or conditions concerning this document’s fitness for a particular purpose or use, its merchantability, or its non-infringement of any third party’s intellectual property rights. CSA Group does not warrant the accuracy, completeness, or currency of any of the information published in this document. CSA Group makes no representations or warranties regarding this document’s compliance with any applicable statute, rule, or regulation.

IN NO EVENT SHALL CSA GROUP, ITS VOLUNTEERS, MEMBERS, SUBSIDIARIES, OR AFFILIATED COMPANIES, OR THEIR EMPLOYEES, DIRECTORS, OR OFFICERS, BE LIABLE FOR ANY DIRECT, INDIRECT, OR INCIDENTAL DAMAGES, INJURY, LOSS, COSTS, OR EXPENSES, HOWSOEVER CAUSED, INCLUDING BUT NOT LIMITED TO SPECIAL OR CONSEQUENTIAL DAMAGES, LOST REVENUE, BUSINESS INTERRUPTION, LOST OR DAMAGED DATA, OR ANY OTHER COMMERCIAL OR ECONOMIC LOSS, WHETHER BASED IN CONTRACT, TORT (INCLUDING NEGLIGENCE), OR ANY OTHER THEORY OF LIABILITY, ARISING OUT OF OR RESULTING FROM ACCESS TO OR POSSESSION OR USE OF THIS DOCUMENT, EVEN IF CSA GROUP HAS BEEN ADVISED OF THE POSSIBILITY OF SUCH DAMAGES, INJURY, LOSS, COSTS, OR EXPENSES.

In publishing and making this document available, CSA Group is not undertaking to render professional or other services for or on behalf of any person or entity or to perform any duty owed by any person or entity to another person or entity. The information in this document is directed to those who have the appropriate degree of experience to use and apply its contents, and CSA Group accepts no responsibility whatsoever arising in any way from any and all use of or reliance on the information contained in this document.

CSA Group is a private not-for-profit company that publishes voluntary standards and related documents. CSA Group has no power, nor does it undertake, to enforce compliance with the contents of the standards or other documents it publishes.

Intellectual property rights and ownership

As between CSA Group and the users of this document (whether it be in printed or electronic form), CSA Group is the owner, or the authorized licensee, of all works contained herein that are protected by copyright, all trade-marks (except as otherwise noted to the contrary), and all inventions and trade secrets that may be contained in this document, whether or not such inventions and trade secrets are protected by patents and applications for

patents. Without limitation, the unauthorized use, modification, copying, or disclosure of this document may violate laws that protect CSA Group's and/or others' intellectual property and may give rise to a right in CSA Group and/or others to seek legal redress for such use, modification, copying, or disclosure. To the extent permitted by licence or by law, CSA Group reserves all intellectual property rights in this document.

Patent rights

Attention is drawn to the possibility that some of the elements of this standard may be the subject of patent rights. CSA Group shall not be held responsible for identifying any or all such patent rights. Users of this standard are expressly advised that determination of the validity of any such patent rights is entirely their own responsibility.

Authorized use of this document

This document is being provided by CSA Group for informational and non-commercial use only. The user of this document is authorized to do only the following:

If this document is in electronic form:

- load this document onto a computer for the sole purpose of reviewing it;
- search and browse this document; and
- print this document if it is in PDF format.

Limited copies of this document in print or paper form may be distributed only to persons who are authorized by CSA Group to have such copies, and only if this Legal Notice appears on each such copy.

In addition, users may not and may not permit others to

- alter this document in any way or remove this Legal Notice from the attached standard;
- sell this document without authorization from CSA Group; or
- make an electronic copy of this document.

If you do not agree with any of the terms and conditions contained in this Legal Notice, you may not load or use this document or make any copies of the contents hereof, and if you do make such copies, you are required to destroy them immediately. Use of this document constitutes your acceptance of the terms and conditions of this Legal Notice.



Standards Update Service

CSA/ASC B652:23
January 2023

Title: Accessible dwellings

To register for e-mail notification about any updates to this publication

- go to www.csagroup.org/store/
- click on **Product Updates**

The **List ID** that you will need to register for updates to this publication is **2430606**

If you require assistance, please e-mail techsupport@csagroup.org or call 416-747-2233.

Visit CSA Group's policy on privacy at www.csagroup.org/legal to find out how we protect your personal information.

Canadian Standards Association (operating as "CSA Group"), under whose auspices this National Standard has been produced, was chartered in 1919 and accredited by the Standards Council of Canada to the National Standards system in 1973. It is a not-for-profit, nonstatutory, voluntary membership association engaged in standards development and certification activities.

CSA Group standards reflect a national consensus of producers and users — including manufacturers, consumers, retailers, unions and professional organizations, and governmental agencies. The standards are used widely by industry and commerce and often adopted by municipal, provincial, and federal governments in their regulations, particularly in the fields of health, safety, building and construction, and the environment.

More than 10 000 members indicate their support for CSA Group's standards development by volunteering their time and skills to Committee work.

CSA Group offers certification and testing services in support of and as an extension to its standards development activities. To ensure the integrity of its certification process, CSA Group regularly and continually audits and inspects products that bear the CSA Group Mark.

In addition to its head office and laboratory complex in Toronto, CSA Group has regional branch offices in major centres across Canada and inspection and testing agencies in fourteen countries. Since 1919, CSA Group has developed the necessary expertise to meet its corporate mission: CSA Group is an

A National Standard of Canada is a standard developed by a Standards Council of Canada (SCC) accredited Standards Development Organization, in compliance with requirements and guidance set out by SCC. More information on National Standards of Canada can be found at www.scc.ca.

SCC is a Crown corporation within the portfolio of Innovation, Science and Economic Development (ISED) Canada. With the goal of enhancing Canada's economic competitiveness and social wellbeing, SCC leads and facilitates the development and use of national and international standards. SCC also coordinates Canadian participation in standards development, and identifies strategies to advance Canadian standardization efforts.

Accreditation services are provided by SCC to various customers, including product certifiers, testing laboratories, and standards development organizations. A list of SCC programs and accredited bodies is publicly available at www.scc.ca.

Standards Council of Canada
600-55 Metcalfe Street
Ottawa, Ontario, K1P 6L5
Canada

independent service organization whose mission is to provide an open and effective forum for activities facilitating the exchange of goods and services through the use of standards, certification and related services to meet national and international needs.

For further information on CSA Group services, write to
CSA Group
178 Rexdale Boulevard
Toronto, Ontario, M9W 1R3
Canada



Cette Norme Nationale du Canada est disponible en versions française et anglaise.

Although the intended primary application of this Standard is stated in its Scope, it is important to note that it remains the responsibility of the users to judge its suitability for their particular purpose.

®A trademark of the Canadian Standards Association, operating as "CSA Group"

Accessibility Standards Canada, under whose auspices this National Standard of Canada has been produced, is a Government of Canada departmental corporation mandated through the Accessible Canada Act. This mandate includes the development and revision of standards that can identify, prevent, and remove barriers to accessibility. Accessibility Standards Canada seeks to create standards that are aligned with its vision, where everyone, including people with disabilities, can expect a Canada without barriers and be sure that opportunities and services are fully accessible. Standards developed by Accessibility Standards Canada are designed with the purpose of creating equity for persons with disabilities while taking into consideration national and international best practices, as opposed to focusing on minimum technical requirements. Accessibility Standards Canada is accredited as a Standards Development Organization by the Standards Council of Canada.

Accessibility Standards Canada is engaged in the production of voluntary accessibility standards, which are developed by technical committees using a consensus-based approach. Each technical committee is composed of a balanced group of experts who develop the technical content of a standard. These experts include persons with disabilities, consumers and other users, government and authorities, labour and unions, other standards development organizations, businesses and industry, academic and research bodies, and non-governmental organizations.

All Accessibility Standards Canada standards are developed through consensus of the views expressed by such experts. These voluntary standards apply to federally regulated entities and can be recommended to the Minister responsible for the Accessible Canada Act (i.e., the Minister of Employment, Workforce Development and Disability Inclusion).

Accessibility Standards Canada
320, St-Joseph Boulevard
Suite 246
Gatineau, QC K1A 0H3
Info.Accessibility.Standards-
Normes.Accessibilite.Info@canada.
gc.ca
accessible.canada.ca



Accessibility Standards
Canada

Normes d'accessibilité
Canada

National Standard of Canada

CSA/ASC B652:23

Accessible dwellings



*®A trademark of the Canadian Standards Association,
operating as "CSA Group"*



Published in January 2023 by CSA Group
A not-for-profit private sector organization
178 Rexdale Boulevard, Toronto, Ontario, Canada M9W 1R3
1-800-463-6727 • 416-747-4044

To purchase standards and related publications, visit our Online Store at www.csagroup.org/store/ or call toll-free 1-800-463-6727 or 416-747-4044.

ICS 91.040.30
ISBN 978-1-4883-4658-3

© 2023 Canadian Standards Association
All rights reserved. No part of this publication may be reproduced in any form whatsoever without the prior permission of the publisher.

Contents

Technical Committee on Accessibility	6
Subcommittee on Accessible Dwellings	11
Preface	13
0 Introduction	15
0.1 Overview	15
0.2 Background	15
0.3 Users	16
1 Scope	16
1.1 Application	16
1.2 Conflicting requirements	17
1.3 Dimensions	17
1.4 Terminology	17
2 Reference publications	18
3 Definitions	18
4 General requirements	21
4.1 General	21
4.2 Distribution of accessible dwellings	21
4.3 Dwelling accessibility	22
4.3.1 Multi-storey accessible dwellings	22
4.3.2 Exterior	22
4.3.3 Parking and garages	23
4.3.4 Dwelling essentials	23
4.3.5 Access within a dwelling	24
4.4 Area allowances	25
4.4.1 Accessible paths of travel	25
4.4.2 Clear floor spaces	25
4.4.3 Knee and toe clearances	26
4.5 Operating controls	32
4.5.1 General	32

4.5.2	Floor area	33
4.5.3	Height	33
4.5.4	Reach ranges	34
4.5.5	Operation	38
4.5.6	Control devices	39
4.5.7	Visual displays	39
4.5.8	Illumination	39
4.5.9	Luminance (colour) contrast	40
4.6	Floor or ground surfaces	40
4.6.1	General	40
4.6.2	Carpet or carpet tiles	41
4.6.3	Thresholds and transitions	41
4.6.4	Gratings and floor vents	44
4.7	Headroom and protruding objects	45
4.7.1	Headroom	45
4.7.2	Protruding objects	48
4.8	Illumination (lighting)	51
4.8.1	General	51
4.8.2	Task lighting	51
4.8.3	Hardwiring	51
4.9	Windows	53

5 Specific design elements 54

5.1	General	54
5.2	Exterior route and landscaping	54
5.2.1	Exterior route	54
5.2.2	Landscaping	56
5.3	Parking space	57
5.3.1	General	57
5.3.2	Area allowances	58
5.3.3	Garages	59
5.3.4	Car ports	60
5.3.5	Height allowances	62
5.4	Exterior amenities	62
5.5	Ramps	63
5.5.1	Running slope and length	63

5.5.2	Cross slope	65
5.5.3	Width	65
5.5.4	Landings	65
5.5.5	Surfaces	69
5.5.6	Edge protection	69
5.5.7	Illumination	71
5.5.8	Handrails	71
5.6	Stairs	75
5.6.1	Treads and risers	75
5.6.2	Nosing	77
5.6.3	Handrails	78
5.6.4	Exterior stairs	82
5.7	Doors and doorways	83
5.7.1	Opening width	83
5.7.2	Manoeuvring area at doors	84
5.7.3	Two doors in series	87
5.7.4	Thresholds	88
5.7.5	Door hardware	89
5.7.6	Door-opening force	91
5.7.7	Power-assisted doors	91
5.7.8	Door viewers	92
5.7.9	Vision panels and side lights	93
5.7.10	Communication systems	93
5.8	Interior circulation	94
5.8.1	Accessible path of travel — Horizontal	94
5.8.2	Accessible path of travel — Vertical	95
5.8.3	Emergency egress	96
5.9	Bathroom(s)	97
5.9.1	General	97
5.9.2	Turning space	97
5.9.3	Doors	100
5.9.4	Floors	100
5.9.5	Wall reinforcing	100
5.9.6	Illumination	105
5.9.7	Windows	106
5.9.8	Electrical	106

5.9.9	Luminance (colour) contrast	107
5.9.10	Toilet and accessories	107
5.9.11	Grab bars	111
5.9.12	Sink and vanity	113
5.9.13	Shower(s)	114
5.9.14	Bathtubs	118
5.9.15	Medicine cabinets	119
5.9.16	Other storage	120
5.10	Kitchens	120
5.10.1	Floor area at appliances and countertops	120
5.10.2	Doors	127
5.10.3	Floors and walls	127
5.10.4	Illumination	127
5.10.5	Electrical	127
5.10.6	Counters	128
5.10.7	Sink	129
5.10.8	Storage	129
5.10.9	Appliances	130
5.11	Bedrooms	133
5.11.1	Area requirements	133
5.11.2	Floors	137
5.11.3	Illumination	137
5.11.4	Windows	138
5.11.5	Electrical	138
5.11.6	Outlet connections	138
5.12	Laundry	139
5.12.1	General	139
5.12.2	Area allowances	139
5.12.3	Features and appliances	139
5.12.4	Doors	139
5.12.5	Floor	139
5.12.6	Illumination	139
5.12.7	Sink	139
5.12.8	Washer and dryer	140
5.12.9	Folding surface	141
5.12.10	Storage	141

5.12.11 Ironing board	142
5.13 Closets	142
5.14 Home automation	143
5.15 Service rooms and spaces	144
5.16 Alert and signal devices	145

Technical Committee on Accessibility

M. Gallant	Department of National Defence, Ottawa, Ontario, Canada Category: Regulatory Authority	Chair
C. Sutton	Wavefront Centre for Communication Accessibility, Vancouver, British Columbia, Canada Category: User Interest	Vice-Chair
P. Acquisto	Pro Accessibility Ltd., Woodbridge, Ontario, Canada Category: Supplier/Fabricator/ Contractor	
J. Apgar	Diebold Nixdorf, North Canton, Ohio, USA	Non-voting
D. Castell	TD Merchant Solutions, Toronto, Ontario, Canada	Non-voting
B. Dion	Betty Dion Enterprises Ltd., Ottawa, Ontario, Canada Category: General Interest	
F. Donati	Fanshawe College, London, Ontario, Canada	Non-voting

T. Freeborn	Coalition of Persons with Disabilities Newfoundland and Labrador, St John's, Newfoundland and Labrador, Canada Category: General Interest	
A. Hammer	Metrolinx, Toronto, Ontario, Canada Category: User Interest	
C. Hanson	Lixil Canada Inc., Mississauga, Ontario, Canada Category: Supplier/Fabricator/ Contractor	
S. Holten	SPH Planning & Consulting Ltd., Toronto, Ontario, Canada	Non-voting
C. Joseph	Accessibility Standards Canada/Government of Canada, Gatineau, Québec	Non-voting
H. Lamb	Spinal Cord Injury BC, Prince George, British Columbia, Canada Category: User Interest	
J. Leenhouts	Employment and Social Development Canada (ESDC), Vancouver, British Columbia, Canada	Non-voting
S. Libera	Queen's University, Toronto, Ontario, Canada	Non-voting

- L. A. MacDonald** Pretium Engineering,
Toronto, Ontario, Canada
Category: General Interest
- C. McLeod** Kohler Co.,
Kohler, Wisconsin, USA
Category: Supplier/Fabricator/
Contractor
- J. Mycan** Toronto Metropolitan
University,
Toronto, Ontario, Canada
Category: User Interest
- C. E. Nicol** Community Advocate for
Accessibility,
Toronto, Ontario, Canada
Category: User Interest
- D. J. Nimchuk** Bank of Montreal,
Toronto, Ontario, Canada
Category: User Interest
- A. C. Novak** KITE Research Institute,
University Health Network,
Toronto, Ontario, Canada
Category: General Interest
- B. Potvin** National Research Council —
Codes Canada,
Ottawa, Ontario, Canada
Category: Regulatory Authority
- S. Rajan** Canadian Transportation
Agency,
Gatineau, Québec, Canada
Category: Regulatory Authority

S. M. Rawalpindiwalla	Kohler, Wisconsin, USA	Non-voting
A. Read	FBM Architecture and Interior Design, Halifax, Nova Scotia, Canada Category: User Interest	
J. Redmond	J. Redmond Consulting Inc., Winnipeg, Manitoba, Canada Category: User Interest	
N. Reid	Coalition of Persons with Disabilities Newfoundland and Labrador, St. John's, Newfoundland and Labrador, Canada	Non-voting
S. A. Remedios	Remedios Consulting, London, Ontario, Canada Category: General Interest	
J. Rogers	Government of Nova Scotia, Department of Municipal Affairs and Housing, Dartmouth, Nova Scotia, Canada	Non-voting
S. Ryan	ABE Factors Inc., Simcoe, Ontario, Canada	Non-voting
M. Sigler	International Code Council, Orlando, Florida, USA	Non-voting

V. T. Taillefer	Public Services and Procurement Canada — National Capital Area Project Delivery (NCAPD), Gatineau, Québec, Canada Category: User Interest	
K. Thompson	Plumbing Manufacturers International, McLean, Virginia, USA Category: Supplier/Fabricator/ Contractor	
S. Winters	Transport Canada, Ottawa, Ontario, Canada Category: Regulatory Authority	
S. Fetterly	CSA Group, Toronto, Ontario, Canada	Project Manager
S. Singh	CSA Group, Toronto, Ontario, Canada	Project Manager

Subcommittee on Accessible Dwellings

S. Ryan	ABE Factors Inc., Simcoe, Ontario, Canada	Chair
M. Gallant	Department of National Defence, Ottawa, Ontario, Canada	Vice-Chair
T. Leblanc	Annapolis Valley Farms, Wolfville, Nova Scotia, Canada	Vice-Chair
M. Courage	Enabling Access Inc., Winnipeg, Manitoba, Canada	
S. Crump	Universal Access, Calgary, Alberta, Canada	
P. Dionne	Régie du bâtiment du Québec, Montréal, Québec, Canada	
L. Greco	The CNIB Foundation, Calgary, Alberta, Canada	
C. Joseph	Accessibility Standards Canada/Government of Canada, Gatineau, Québec, Canada	
H. Lamb	Spinal Cord Injury BC, Prince George, British Columbia, Canada	

F. Lohmann	Canadian Home Builders' Association, Ottawa, Ontario, Canada	
J. Marriott	Rick Hansen Foundation, Richmond, British Columbia, Canada	
C. McLeod	Kohler Co., Kohler, Wisconsin, USA	
K. Ng	Rick Hansen Foundation, Toronto, Ontario, Canada	
T. Petkau	Habitat for Humanity, Toronto, Ontario, Canada	
J. Sawchuk	Sawchuk Accessible Solutions Inc., Blyth, Ontario, Canada	
J. St-Amant	HealthCraft Products Inc., Ottawa, Ontario, Canada	
S. Fetterly	CSA Group, Toronto, Ontario, Canada	Project Manager
S. Singh	CSA Group, Toronto, Ontario, Canada	Project Manager

Preface

This is the first edition of CSA/ASC B652, Accessible dwellings.

CSA Group acknowledges that the development of this Standard was made possible, in part, by the financial support of the Canada Mortgage and Housing Corporation (CMHC).

The technical requirements in this Standard are minimum levels. They represent a consensus of the Technical Committee members, who represent a broad spectrum of interests. The members are helped and encouraged by the public comments received as a result of the wide distribution of a draft at the public review stage.

This Standard is considered suitable for use for conformity assessment within the stated scope of the Standard.

This Standard was prepared by the Subcommittee on Accessible Dwellings, under the jurisdiction of the Technical Committee on Accessibility and the Strategic Steering Committee on Health and Well-Being, and has been formally approved by the Technical Committee.

This Standard has been developed in compliance with Standards Council of Canada requirements for National Standards of Canada. It has been published as a National Standard of Canada by CSA Group.

Notes:

- 1) Use of the singular does not exclude the plural (and vice versa) when the sense allows.
- 2) Although the intended primary application of this Standard is stated in its Scope, it is important to note that it remains the responsibility of the users of the Standard to judge its suitability for their particular purpose.
- 3) This Standard was developed by consensus, which is defined by CSA Policy governing standardization — Code of good practice

for standardization as “substantial agreement. Consensus implies much more than a simple majority, but not necessarily unanimity”. It is consistent with this definition that a member may be included in the Technical Committee list and yet not be in full agreement with all clauses of this Standard.

- 4) To submit a request for interpretation of this Standard, please send the following information to inquiries@csagroup.org and include “Request for interpretation” in the subject line:
 - a) define the problem, making reference to the specific clause, and, where appropriate, include an illustrative sketch;
 - b) provide an explanation of circumstances surrounding the actual field condition; and
 - c) where possible, phrase the request in such a way that a specific “yes” or “no” answer will address the issue.Committee interpretations are processed in accordance with the CSA Directives and guidelines governing standardization and are available on the Current Standards Activities page at standardsactivities.csa.ca.
- 5) This Standard is subject to review within five years from the date of publication. Suggestions for its improvement will be referred to the appropriate committee. To submit a proposal for change, please send the following information to inquiries@csagroup.org and include “Proposal for change” in the subject line:
 - a) Standard designation (number);
 - b) relevant clause, table, and/or figure number;
 - c) wording of the proposed change; and
 - d) rationale for the change.

CSA/ASC B652:23

Accessible dwellings

0 Introduction

0.1 Overview

This Standard contains requirements and recommendations for making dwellings accessible to people with a range of physical, sensory, or cognitive disabilities, or a combination thereof, including but not limited to those that involve mobility, reaching, manipulation, hearing, visual, etc. It was developed in response to an expressed need for a national technical standard that covers accessible housing. The technical requirements and recommendations in this Standard cover design elements of the physical spaces in housing to help ensure they are accessible to people with a wide range of abilities and disabilities.

This Standard also supports principles of Universal Design as it applies to housing, i.e., designing livable environments so that people can access, understand, and use their homes to the greatest extent possible, regardless of their age, size, ability, or disability. An accessible residence might still require adaptability on behalf of the individual living in the home based on their specific needs and preferences. This Standard aims to make it easier for someone to make adaptations to their home in pursuit of improved living.

0.2 Background

Current design and construction guidelines and codes for accessible dwellings vary by jurisdiction across Canada and the requirements tend to be limited. Most traditional home models are not designed with accessibility in mind, making alterations to existing homes challenging. Policy-makers and consumers have identified a need to provide more housing stock that is

accessible, affordable, and adaptable for older adults and people with disabilities. The goal of this Standard is to provide evidence-informed guidance and best practices for the design, construction, and alteration of accessible homes. Individuals with lived experience were actively involved in the development of this Standard.

0.3 Users

This Standard is intended to assist those who are seeking to provide, offer, design, construct, or alter more accessible, affordable, and adaptable home options for people with disabilities. This Standard will also provide comprehensive guidance to other stakeholders interested in accessible housing, including consumers, policy-makers, certification organizations, researchers, and non-governmental organizations.

1 Scope

1.1 Application

This Standard can be used in the design and construction of new homes, or in alterations to existing housing, as it pertains to accessibility. This includes the design, construction, and alteration of built environments leading up to, into, and throughout accessible dwellings.

The requirements in this Standard are suitable for permanent dwellings, short-term dwellings and visitable dwellings. This includes accommodations such as detached houses, semi-detached houses, houses with a secondary suite, duplexes, triplexes, townhouses, row houses and boarding houses, apartments or condominiums, and communal residential dwellings (e.g., hotels/motels, hostels, dormitories, care facilities).

Multi-unit residential accommodations with shared common elements outside the dwelling (e.g., shared parking, exterior

and interior paths of travel outside of the dwelling, amenity spaces, washrooms located outside of dwellings, etc.) are addressed in CSA/ASC B651.

1.2 Conflicting requirements

This Standard does not address the application of technical requirements and recommendations through regulations or conformity assessment schemes. In cases where a requirement or method in another standard that is referenced in a regulation conflict with recommendations in this Standard, the regulatory requirements take precedence.

1.3 Dimensions

The values given in SI units are the units of record for the purposes of this Standard. The values given in parentheses are for information and comparison only.

This Standard contains minimum requirements based on adult dimensions. Where converted from non-SI units, values have been rounded off with respect to critical dimensions.

All dimensions in figures are given in millimetres (mm) and are measured to the centreline, unless otherwise specified.

1.4 Terminology

In this Standard, “shall” is used to express a requirement, i.e., a provision that the user is obliged to satisfy in order to comply with the standard; “should” is used to express a recommendation or that which is advised but not required; and “may” is used to express an option or that which is permissible within the limits of the Standard.

Notes accompanying clauses do not include requirements or alternative requirements; the purpose of a note accompanying a clause is to separate from the text explanatory or informative material.

Notes to tables and figures are considered part of the table or figure and may be written as requirements.

2 Reference publications

This Standard refers to the following publications, and where such reference is made, it shall be to the edition listed below.

CSA Group

CSA/ASC B651:23

Accessible design for the built environment

ASME A17.1-2019/CSA B44:19

Safety code for elevators and escalators

CSA B355:19

Platform lifts and stair lifts for barrier-free access

CAN/CSA-B613-00 (R2012)

Private residence lifts for persons with physical disabilities

3 Definitions

The following definitions shall apply in this Standard:

Accessible — as applied to a site, building, or other facility, possessing the necessary characteristics for it to be entered, exited, and used by people, including those with physical, sensory, communication, or cognitive disabilities.

Accessible path of travel — a route within an interior or exterior environment that is without barriers and usable by all people, including those with disabilities.

Assistive mobility device — a collective term to describe a range of personal transportation devices, including manual

wheelchairs, powered wheelchairs, scooters, walkers, crutches, and canes.

Note: Where a Clause in this Standard applies to a single type of mobility device, the specific term (e.g., “manual wheelchair”, “powered wheelchair”, “scooter”) will be used.

Dual-purpose grab bars — grab bars with additional built-in components that provide other functions (e.g., grab bars that incorporate components for shelves, towel rails, or toilet paper dispensers).

Dwelling — a housekeeping unit used or intended to be used by one or more people and usually contains cooking, eating, living, sleeping, and sanitary facilities.

Glare — an excessive reflection of light from a surface.

Home alterations — alterations that include but are not limited to remodeling, modifying, renovating, rehabilitating, reconstructing, restoring, or making changes to an existing residence.

Illumination — the intensity of light, as measured in lux (lx).

Luminance — the intensity of light emitted or reflected in a given direction from the surface element divided by the area of the element in the same direction.

Luminance (colour) contrast — the difference in light reflectance value between adjacent surfaces (e.g., light on a dark background or dark on a light background).

Note: See CSA/ASC B651 for measurement methods and guidance regarding the general application of luminance (colour) contrast.

Main entrance — the “front door” that typically faces a street.

Multi-residential building — a structure containing multiple separate housing units for residential occupancy, or a situation where more than one housing units are situated within the same complex or development.

Permanent — in relation to residential accommodation, a term used to describe any dwelling (house, semi-detached, duplex, row house, multiplex, townhouse, condominium, or apartment) that one or more persons live in as their primary residence.

Ramp — a sloping walkway leading from one level to another that has a running slope with a ratio steeper than or equal to 1:20 (5%).

Short-term accommodation — any hotel/motel, hostel, education residence, emergency shelter, or other communal residence that one or more persons occupy temporarily.

Slope — the ratio of rise to run on an inclined surface.

Cross slope — the slope that is perpendicular to the direction of travel.

Running slope — the slope that is parallel to the direction of travel.

Task lighting — lighting that provides enhanced illumination concentrated in a specific area.

Transfer space — an unobstructed area that allows for the positioning of an assistive mobility device in such a way as to enable a person to transfer to another adjacent seated position.

Visitable — in relation to residential accommodation, any dwelling that offers a basic level of access to accommodate visitors such as people who use a wheeled mobility aid, people who are elderly, or residents who might have a temporary disability. Visitable dwellings allow a person to enter a dwelling safely, manoeuvre independently throughout the visitable level, and use the toilet facilities.

4 General requirements

4.1 General

Where accessible residential dwellings form part of a multi-unit residential building (e.g., apartment or condominium), all common exterior and interior spaces outside of the residential unit itself should comply with the provisions set out in this Clause and in CSA/ASC B651.

Notes:

- 1) Because of the broad application of the Standard's requirement, it is recommended that all multi-unit residential building projects include accessible dwellings.
- 2) Construction, furnishing, or decorative materials should not give off gases that affect the quality of indoor air. Contaminants such as gases, dust, and volatile organic compounds should be minimized. Adequate ventilation (natural and mechanical) should be provided at the level needed to dilute any contaminants and to provide fresh air to the occupants.

4.2 Distribution of accessible dwellings

The distribution of accessible dwellings within a multi-residential building project should be as follows:

- a) The number and size (e.g., 0 to 3 bedrooms) of accessible dwellings should be proportional to the number and size of all dwellings being provided.
- b) The location of stacked accessible dwellings (such as apartments or in a condominium) should
 - i) be proportionally distributed between levels; and
 - ii) offer different views.
- c) Dwellings should be distributed throughout floor levels so as to offer choice of location.
- d) Where accessible dwellings are part of a development including single-family dwellings, townhouses, triplexes or

similar, they should be proportionally distributed as to provide choice of street, corner, or middle dwelling.

Note: The distribution of accessible dwellings should consider proximity to conveniences such as elevators, parking, and amenities.

4.3 Dwelling accessibility

4.3.1 Multi-storey accessible dwellings

Where a dwelling is more than one storey, it shall comply with Clause [5.8.2](#).

4.3.2 Exterior

Exterior paths serving an accessible dwelling shall be designed as follows:

- a) Up to the main entrance, be it from a sidewalk, driveway, or garage, an accessible dwelling shall be served by
 - i) an accessible path of travel in accordance with Clause [4.4.1](#); or
 - ii) a ramp conforming to Clause [5.5](#).
- b) Where an accessible dwelling is provided with a balcony, backyard, or access to an outdoor amenity space on the first storey, such space shall be served by
 - i) an accessible path of travel in accordance with Clause [4.4.1](#); or
 - ii) a ramp in accordance with Clause [5.5](#); and
 - iii) have a minimum clear floor space in accordance with Clause [4.4.2](#) b).
- c) Where interior and exterior access is available, both shall be served by an accessible path of travel as required in Clause [4.3.2](#) b).

Notes:

- 1) Exterior unprotected lifts are not advised for new construction projects and are not ideal for exterior environments unless otherwise protected from environment conditions.

- 2) Where access to a backyard, patio, or balcony is only provided via the interior of the dwelling or unit, accessible access need only be provided from the interior. This ensures that someone can get to those spaces based on available routes offered by the design.
- 3) Where there is no yard or grassy area, consider a service dog relief area.

4.3.3 Parking and garages

Accessible dwellings with driveways and garages shall be designed as follows:

- a) At minimum, where the accessible dwelling has a driveway and garage, access shall be provided into the home from the main entrance and garage entrance by
 - i) an accessible path of travel in accordance with Clause [4.4.1](#); or
 - ii) a ramp in accordance with Clause [5.5](#).
- b) If accessible parking or garages are provided, accessible dwellings shall have
 - i) accessible parking designed in accordance with Clause [5.3.2](#); and
 - ii) garages designed in accordance with Clause [5.3.3](#).
- c) Parking, amenity spaces, lobbies, waiting areas, and accessible paths of travel outside of or leading up to accessible dwellings within a multi-unit residential building shall conform to CSA/ASC B651.

Note: For people with disabilities, entering or exiting a home can become difficult because of elevation changes such as stairs or steps at a dwelling's entrance. If the main floor is 600 to 900 mm above ground level, a long ramp (of 10 to 20 m) is likely required. The goal is to have a continuous, step-free pathway from the street entrance or parking area to a dwelling entrance that is level.

4.3.4 Dwelling essentials

Regardless of whether a dwelling is intended for a person with a disability, every individual who seeks to live in that home shall

have access to and use of the following three essentials of daily life:

- a) nourishment (e.g., kitchen/dining);
- b) cleansing/personal hygiene (e.g., bathroom, laundry); and
- c) rejuvenation (e.g., bedroom, living room, den, family room).

This requirement shall apply when designing a new dwelling unit or modifying an existing one.

4.3.5 Access within a dwelling

4.3.5.1 General

To ensure someone with a disability can fully use their home, access to all rooms and spaces within the dwelling is of utmost importance. For example, if a second-floor level encompasses bedrooms, a person with a disability must be able to gain access to all bedrooms within the dwelling, regardless of whether there is a designated accessible bedroom on the main level. All rooms and spaces within an accessible dwelling shall

- a) be served by
 - i) an accessible path of travel in accordance with Clause [4.4.1](#); or
 - ii) a ramp in accordance with Clause [5.5](#);
- b) have operating controls in accordance with Clause [4.5](#);
- c) have flooring and ground surfaces in accordance with Clause [4.6](#);
- d) maintain headroom clearances in accordance with Clause [4.7](#);
- e) be illuminated in accordance with Clause [4.8](#); and
- f) have windows in accordance with Clause [4.9](#).

4.3.5.2 Doors

Doors serving accessible dwellings shall comply with Clause [5.7](#).

Notes:

- 1) The entry into a visitable dwelling unit should be the main entrance to the unit. Where this is not possible, an alternative entrance may be used as the visitable entrance, including an entrance from an attached garage, an entrance along the side of a dwelling unit, or one from the rear.
- 2) Wayfinding strategies, including signage and entrance design, should be used to help with orientation.

4.3.5.3 Rooms and spaces

Accessible dwellings shall have at least

- a) one bathroom in accordance with Clause [5.9](#);
- b) one kitchen in accordance with Clause [5.10](#);
- c) one bedroom in accordance with Clause [5.11](#); and
- d) one laundry in accordance with Clause [5.12](#).

4.4 Area allowances

4.4.1 Accessible paths of travel

Accessible paths of travel shall have a width at least

- a) 1200 mm for the interior environment, except for home alterations where a minimum of 1000 mm is acceptable; and
- b) 1500 mm for the exterior environment, except for home alterations where a minimum of 1000 mm is acceptable.

4.4.2 Clear floor spaces

Clear floor or ground spaces to accommodate a person who uses an assistive mobility device shall be

- a) at least 820 mm by 1390 mm for a stationary position (see Figure [1](#));

- b) at least
 - i) an 1800 mm turning diameter [see Figure [2 a\)](#)] for new construction;
 - ii) a 1500 mm turning diameter for home alterations; and
 - iii) for short-term accommodation, comply with CSA/ASC B651 and be at least 2100 by 2100 mm; and
- c) at least 1800 mm by 1200 mm by 1200 mm for a T-turn (see Figure [3\)](#) for new construction, and 1500 mm by 1000 mm by 1000 mm for alterations.

Notes:

- 1) Where possible, a minimum 1800 mm turning diameter is recommended for all applications.
- 2) Where possible, a minimum 1800 mm by 1200 mm by 1200 mm T-turn is recommended for all cases.
- 3) Larger assistive mobility devices, such as some power wheelchairs and scooters, require more space to complete a 180° U-turn. In these cases, consider increasing the minimum floor area to 2100 by 2100 mm [see Figure [2 b\)](#)] for larger powered assistive mobility devices and 3150 by 3150 mm [see Figure [2 c\)](#)] for scooters.

4.4.3 Knee and toe clearances

Counter heights and work surfaces (or portions of work surfaces) should be provided with a knee clearance centred on the element (e.g., cooktop, sink) that has a rim or surface height between 730 and 860 mm above the floor, and with a clearance below not less than

- a) 820 mm wide;
- b) 685 mm to 730 mm high at the underside of the front edge;
- c) At least 685 mm high at a point 200 mm back from the front edge;
- d) beyond a point 200 mm back, have a toe clearance not less than 820 mm wide by 230 mm deep and 230 mm high; and
- e) have a minimum 1390 mm deep floor space to allow for forward approach, of which up to 480 mm of the clear floor

space is permitted to extend below the element (see Figure 4).

Note: The dimensions outlined in Clause 4.4 allow for accessibility and address the ergonomics of these workstations so people can conduct their daily tasks, from a seated or standing position, in such a manner that encourages the prevention of musculoskeletal injuries and promotes wellness at home.

Figure 1
Clear floor area for a person using an assistive mobility device
(suitable for manual wheelchair, powered wheelchair, or scooter)
(See Clause 4.4.2.)

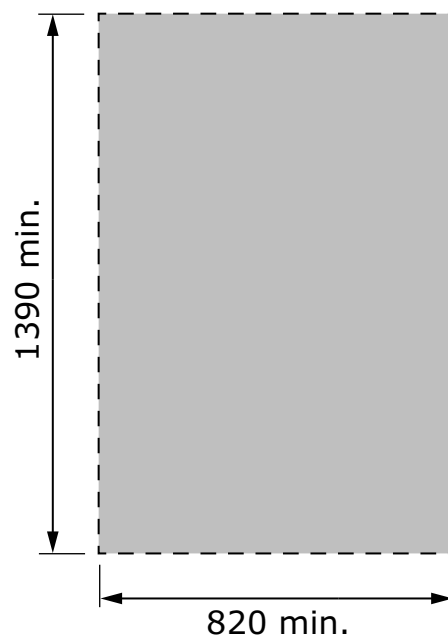

This figure shows a clear floor area with a minimum length of 1390 mm and a minimum width of 820 mm.

Note: All dimensions are in mm.

Figure 2 a)
Minimum floor area at the toe level for a person
using an assistive mobility device (manual
wheelchair, powered wheelchair, or scooter) to
make a 180° U-turn
(See Clause [4.4.2.](#))

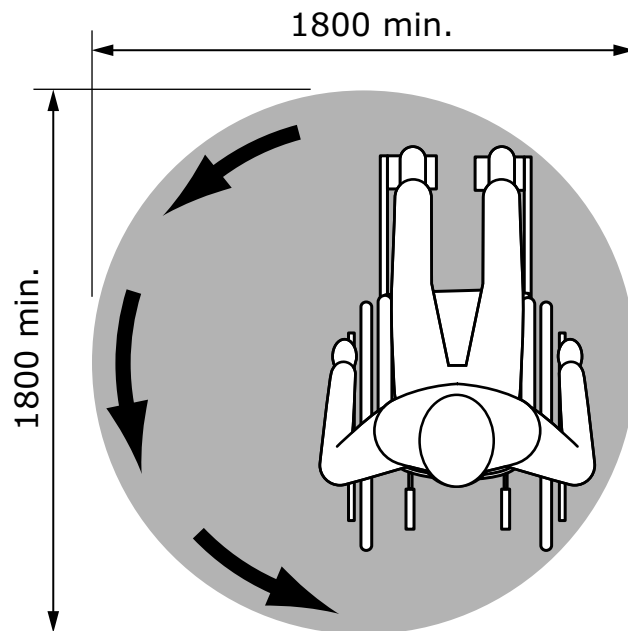

This figure shows a person sitting in a manual wheelchair, with a circle indicating a minimum turning diameter of 1800 mm.

Note: All dimensions are in mm.

Figure 2 b)
Minimum floor area for a larger powered assistive mobility device
(See Clause [4.4.2.](#))

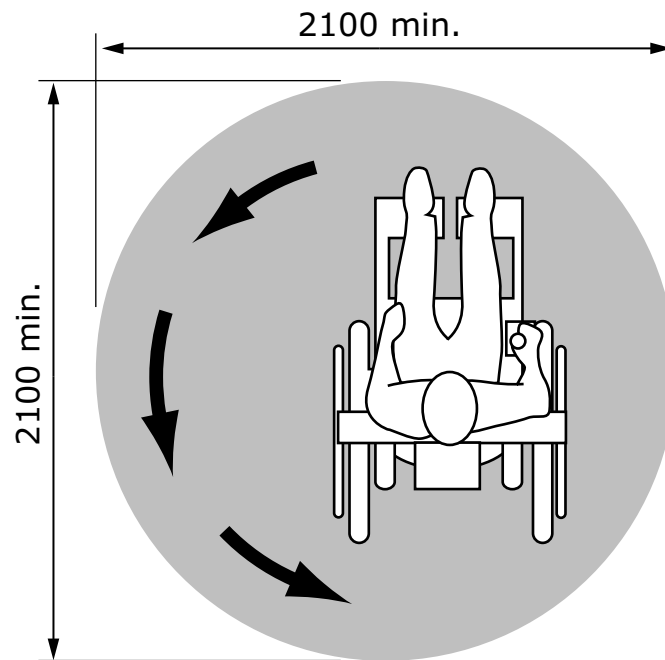

This figure shows a person sitting in a larger powered assistive mobility device, with a circle indicating a minimum turning diameter of 2100 mm.

Note: All dimensions are in mm.

Figure 2 c)
Minimum floor area for a person using a scooter
(See Clause [4.4.2.](#))

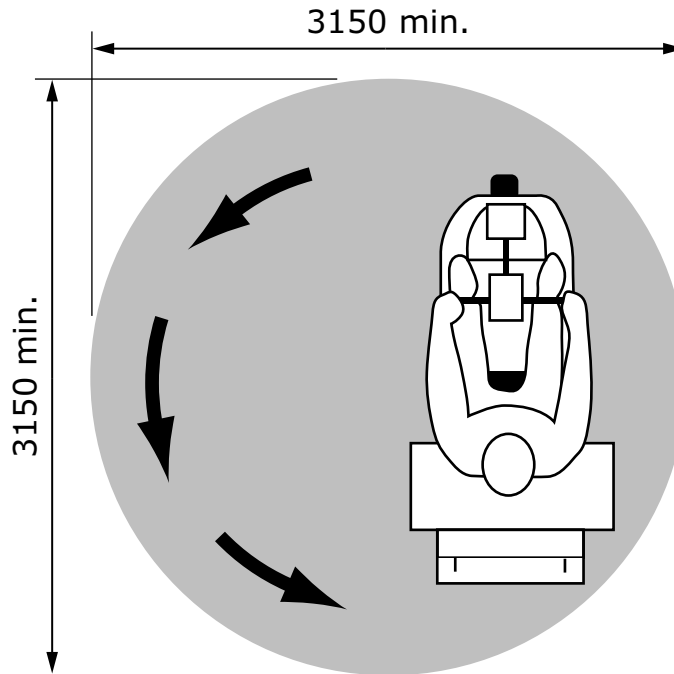

This figure shows a person sitting in a scooter, with a circle indicating a minimum turning diameter of 3150 mm.

Note: All dimensions are in mm.

Figure 3
Minimum floor area at the toe level for a person
using an assistive mobility device to make a T-turn
 (See Clause [4.4.2.](#))

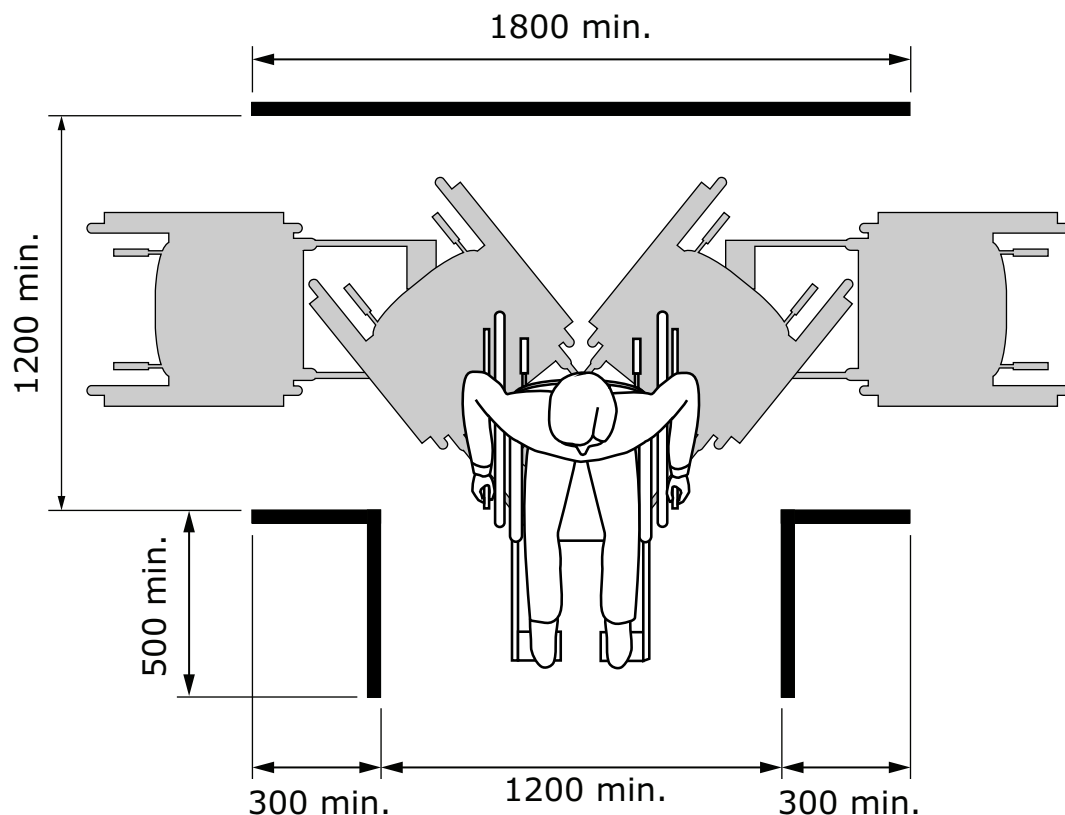

This figure shows a person in a wheeled mobility device performing a T-turn. The primary hallway where the individual is travelling has minimum dimensions of 1200 mm width by 1800 mm length. The side hallway utilized in the turn has a minimum width of 1200 mm and depth of 500 mm.

Note: All dimensions are in mm.

Figure 4
Minimum knee and toe clearance for a person using
an assistive mobility device
 (See Clause [4.4.3.](#))

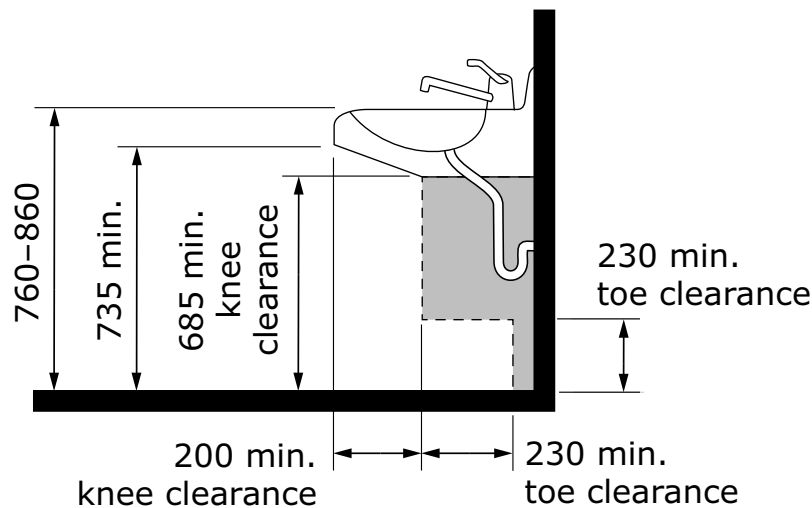

This figure shows the minimum clearances needed around an item that someone could pull up to, in this case a bathroom sink. The top of the basin is depicted as being 760 to 860 mm above the ground, and 685 to 735 mm high at the underside of the front edge. Also depicted is a minimum knee clearance of 685 mm high at a point 200 mm back from the front edge, and minimum toe clearance of 230 mm high by 230 mm deep extending out beyond the 200 mm knee clearance to a total of 430 mm distance behind the front edge of the sink.

Note: All dimensions are in mm.

4.5 Operating controls

4.5.1 General

Operating controls shall include but are not limited to

- door handles and locks;
- window operators and locks;

- c) faucets and adjustable shower heads;
- d) thermostats;
- e) appliances;
- f) doorbells;
- g) intercoms;
- h) electrical receptacles;
- i) electrical panels; and
- j) activation devices (e.g., light switches).

Note: All operation controls within a home that might require operation by a resident or tenant living in the home should be accessible.

4.5.2 Floor area

Controls shall be adjacent to and centred on either the length or the width of a clear floor space of 820 mm by 1390 mm.

Note: A clear floor area of at least 1800 mm by 1800 mm in front of all operating controls provides room for people operating an assistive mobility device to turn and negotiate within the space. This additional room permits the control to be approached from either side.

4.5.3 Height

The centerline of the operating controls shall be located in a range

- a) between 400 and 1100 mm from the floor; and
- b) between 900 and 1100 mm from the floor in situations where reading a display is required (i.e., thermostat, intercom, etc.) (see Figure 5).

Notes:

- 1) When locating a control close to the 400 mm or 1100 mm limits, consider the type of actions required to use or activate that control, especially if a complex action or manipulation is required.
- 2) Adjustability of controls to facilitate their use at a lower height should be considered as part of the design process.

Figure 5
Height of operating controls
 (See Clause [4.5.3.](#))

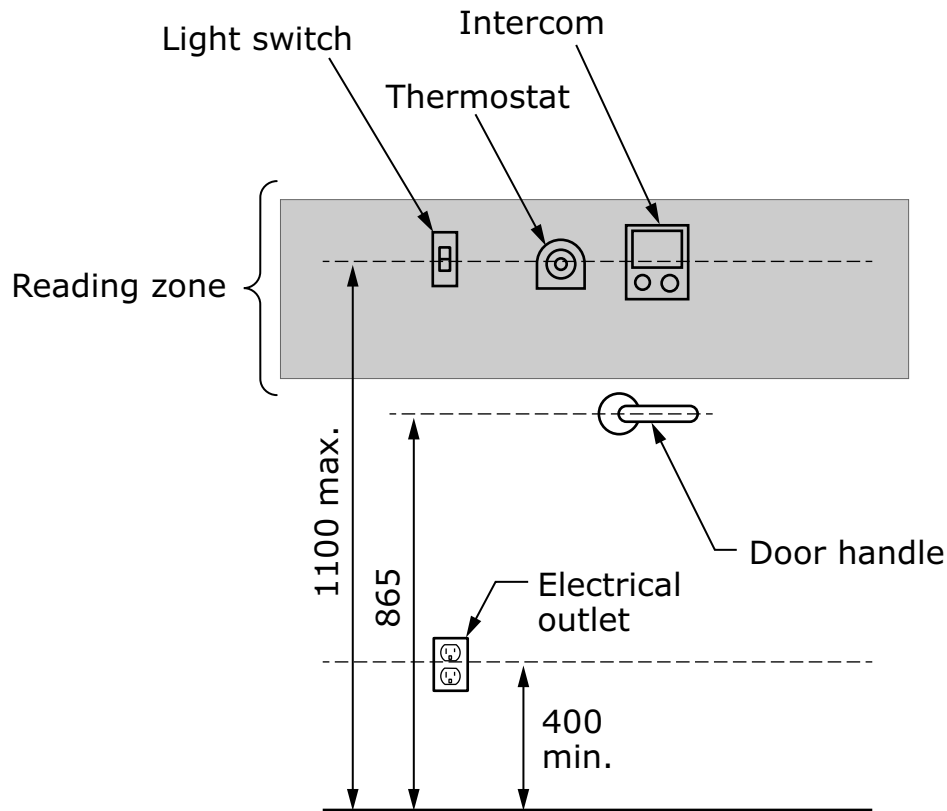

This figure shows the placement of various controls, including a light switch, thermostat, and intercom, with the primary touch point of each control placed 1100 mm from the ground. A door handle is placed at 865 mm from the ground, within the 400 to 1100 mm limits. An electrical outlet placed 400 mm above the ground is also shown.

Note: All dimensions are in mm.

4.5.4 Reach ranges

Where a clear floor space is provided for forward or side approach, the operable control shall be within a

- a) highest forward reach 1100 mm from the floor, which allows for a touch-reach over a 600 mm deep obstruction or a

grasp-reach over a 500 mm deep obstruction (see Figure [6](#));
and

- b) highest side reach over an 860 mm high obstruction 1100 mm from the floor, which allows for a touch-reach depth of 600 mm or a grasp-reach depth of 500 mm (see Figure [7](#)).

Notes:

- 1) As peoples' abilities can vary, a person's actual reach ranges should be taken into account.
- 2) This provision assumes an obstruction height of not more than 860 mm. For example, someone having to reach over a countertop not higher than 860 mm to turn on a light switch mounted along the backsplash should be capable of doing so without having to reach more than 500 mm. If this is not possible, consider relocating the light switch to a more accessible position (e.g., along a side wall or along the front edge of the counter).
- 3) Refer to Table [1](#) for guidance on reduced reach ranges where building elements such as coat hooks or operable parts are designed primarily for children or people of shorter stature.

Figure 6
Forward reach over obstruction
 (See Clause [4.5.4.](#))

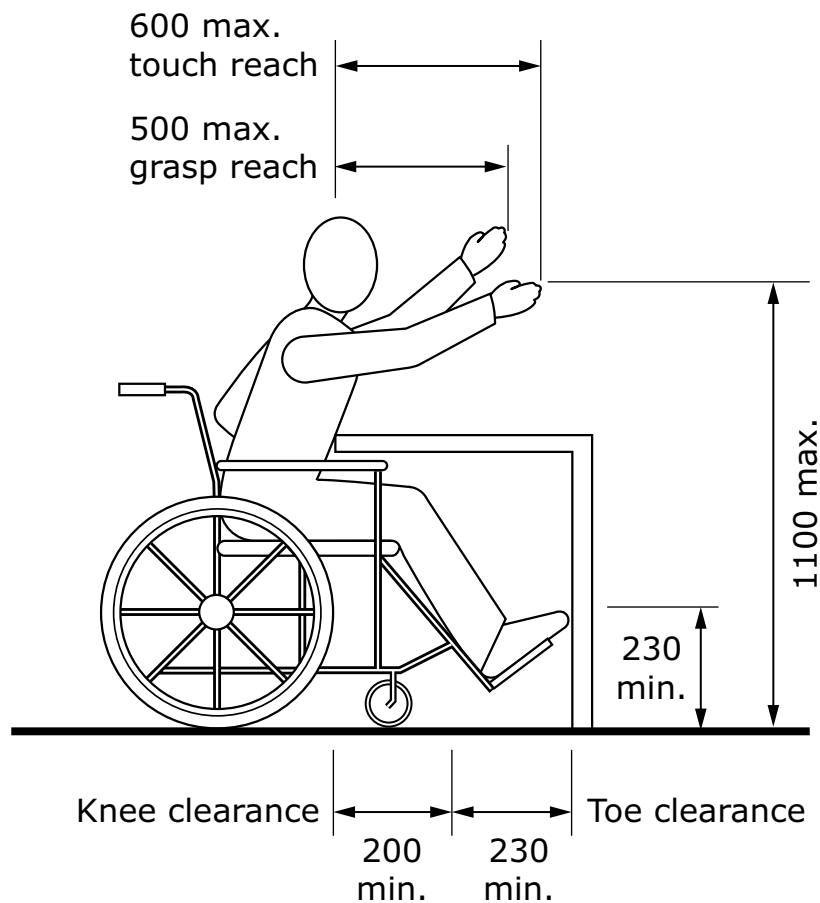

This figure demonstrates the forward reach range for an assistive mobility device user over an obstruction. This is depicted by a person in an assistive mobility device reaching forward over a table that has 430 mm knee clearance. The person's maximum reach height is 1100 mm. Maximum extension is 600 mm for a touch reach, or 500 mm for a grasp reach.

Note: All dimensions are in mm.

Figure 7
Side reach over obstruction
(See Clause [4.5.4.](#))

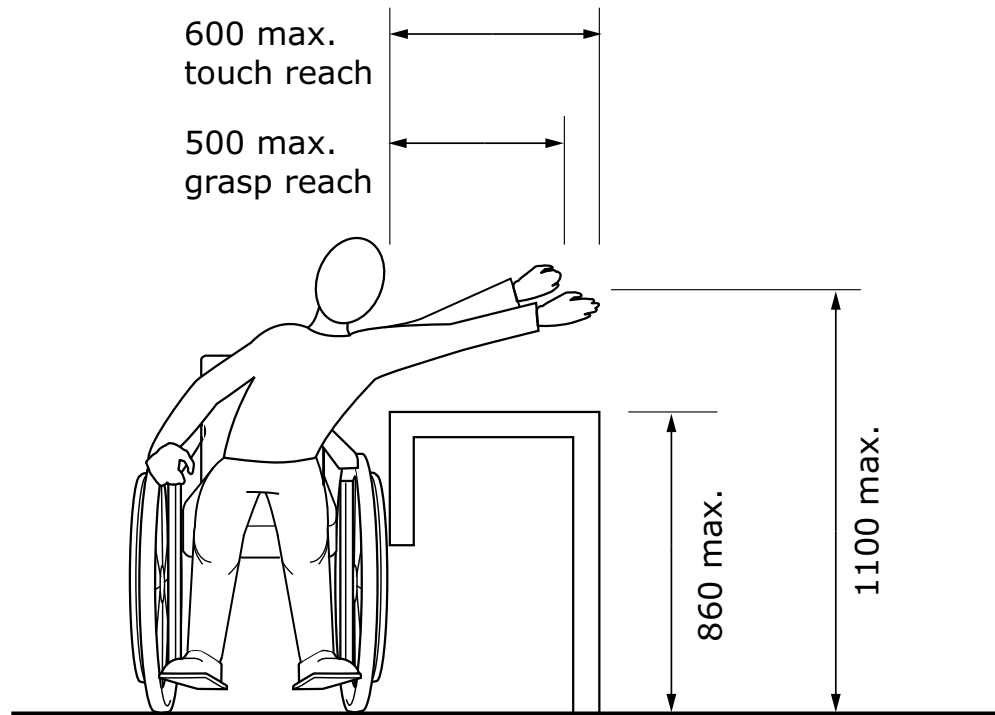

This figure shows a person in an assistive mobility device reaching to the side and over an obstruction that is 860 mm high. The person is able to extend to the side a maximum of 500 mm for a grasp reach, and 600 mm for touch reach, and with a maximum reach height of 1100 mm.

Note: All dimensions are in mm.

Table 1
Reach ranges for people of shorter stature
 (See Clauses [4.5.4](#) and [5.9.12.1](#).)

The table lists the minimum and maximum forward or side reach, in mm, based on age and height ranges for people of shorter stature.

Forward or side reach	Ages 3 and 4 or approx. 950 mm to 1000 mm height	Ages 5 to 8 or approx. 1000 mm to 1270 mm height	Ages 9 to 12 or approx. 1270 mm to 1524 mm height
High (maximum)	915 mm	1015 mm	1120 mm
Low (minimum)	510 mm	455 mm	405 mm

4.5.5 Operation

Controls shall

- a) with the exception of security hardware (e.g., key locks), be operable with one hand using either
 - i) a closed fist; or
 - ii) another method of grasping that does not require tight grasping, pinching, or twisting of the wrist;
- b) be operable with a force not more than 22 N; and
- c) comply with Clause [4.4](#).

Notes:

- 1) Electronic or automated controls can facilitate use by a wider range of people.
- 2) The requirement for operation by one hand does not preclude several operations one after the other. The kind of situation to be avoided might include, e.g., a door lock that has to be turned

with one hand while the door handle is simultaneously turned with the other hand.

- 3) A control that needs to be read or adjusted should be angled in such a way that it is usable from a seated and standing position.

4.5.6 Control devices

Control devices shall be capable of providing or supporting tactile, auditory, or tactile and auditory information to indicate function, position, and confirmation of activation.

Notes:

- 1) Controls with different shapes can help identify different functions.
- 2) As many controls are supplemented by functionality through various smart devices (e.g., mobile devices) that offer both audio and visual functionality, a control device with a supporting application that provides the audible or tactile component will suffice.

4.5.7 Visual displays

Devices with visual display screens shall

- a) be capable of supplementing displayed information with tactile, auditory, or tactile and auditory information;
- b) show information in such a way that it is luminance (colour) contrasted from the display screen background; and
- c) present information on a display surface with low or no glare.

Notes:

- 1) Where a device has a visual display screen, installing it to be easily accessed from a seated and standing position will allow for increased readability and use.
- 2) Glare can often be avoided based on the positioning of the device.

4.5.8 Illumination

Where reading is necessary, operating controls should be illuminated to a level of at least 200 lx.

If an operating control has its own illumination or is backlit, and reading of the surface is not required for operation, an internal or background illumination of 50 to 100 lx may be used.

4.5.9 Luminance (colour) contrast

Operating controls shall be luminance (colour) contrasted with their background (i.e., surroundings).

Note: Luminance (colour) contrast is used to increase visibility of controls. The luminance (colour) contrast can be extended to include a cover plate, if present. For example, to aid someone in finding the light switch, luminance (colour) contrast the cover plate from the switch itself, while ensuring the cover plate luminance (colour) contrasts with the surface to which it is attached.

4.6 Floor or ground surfaces

4.6.1 General

Floor or ground surfaces leading up to, going into, and running throughout an accessible dwelling shall

- a) be secure and stable;
- b) be slip-resistant (when dry or wet);
- c) produce minimal glare or reflection;
- d) not have strong visual patterning; and
- e) unless designed as a ramp, be level except when sloping towards a drain at not more than 1:50 (2%).

Notes:

- 1) Where sloping of interior floor surfaces within an accessible dwelling unit is necessary, the floor surfaces should comply with Clause [4.6.3](#) except when sloping towards a drain.
- 2) Highly reflective surfaces can result in glare, which can be problematic for many people. To avoid glare, consider choosing surfaces that have a matte finish.
- 3) Avoid the use of heavily textured surfaces such as decorative paving in the path of travel, as uneven surfaces can cause difficulty for people with disabilities.

- 4) Avoid busy patterns and multiple colors in flooring, as they can create visual distractions or be mistaken for changes in depth perception.
- 5) Where flooring is provided, it should be installed and maintained in accordance with manufacturers' specifications to avoid deterioration or misapplication.

4.6.2 Carpet or carpet tiles

Where carpet or carpet tiles are used, they should

- a) have a low, firm, and level pile or loop;
- b) have a combined carpet and pad height of not more than 13 mm;
- c) be securely fastened;
- d) comply with Table [2](#) with respect to thresholds and transitions in edge trim; and
- e) be backed or underlaid with firm materials only.

Notes:

- 1) Heavily patterned floor and ground surfaces can cause confusion for people with limited vision and can interfere with wayfinding.
- 2) Carpets or carpet tiles within the home affects the accessibility of homes for people using assistive mobility devices. For example, area rugs and other carpeted surfaces can create potential trip hazards and make it challenging to negotiate when using an assistive mobility device.
- 3) New carpets can produce off-gassing, which can adversely affect people with environmental intolerances. Suppliers can provide carpets that have been off-gassed prior to installation.

4.6.3 Thresholds and transitions

With the exception of elevators, stairs, and elevating devices, changes in level shall comply with Table [2](#) [see Figures [8 a\)](#) to [8 c\)](#)].

Table 2
Thresholds and transitions
 (See Clauses [4.6.2](#) and [4.6.3](#).)

The table outlines the changes in levels for vertical rises in mm.

Vertical rise, mm	Profile
0 to 6	May be vertical [see Figure 8 a)]
7 to 13	Bevelled, but not steeper than the ratio 1:2 (50%) [see Figure 8 b)]
13 to 50	Not steeper than the ratio of 1:12 (8.33%) [see Figure 8 c)]

Figure 8 a)
Changes in level – Up to 6 mm
 (See Clauses [4.6.3](#) and [5.7.4](#), and Table [2](#).)

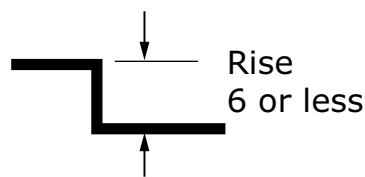

Change in level
up to 6 mm

May be vertical

This figure shows a change in level up to 6 mm as a step increase.

Note: All dimensions are in mm.

Figure 8 b)
Changes in level – 7 to 13 mm
(See Clauses [4.6.3](#) and [5.7.4](#), and Table [2](#).)

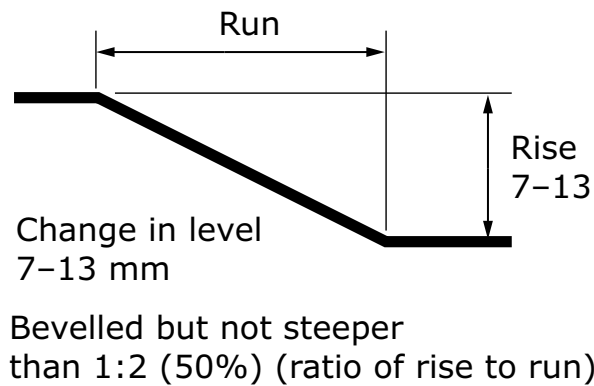

This figure shows a change in level between 7 mm to 13 mm with a slope not steeper than 1:2 (50%) ratio of rise to run.

Note: All dimensions are in mm.

Figure 8 c)
Changes in level — 13 to 50 mm
(See Clause [4.6.3](#) and Table [2.](#))

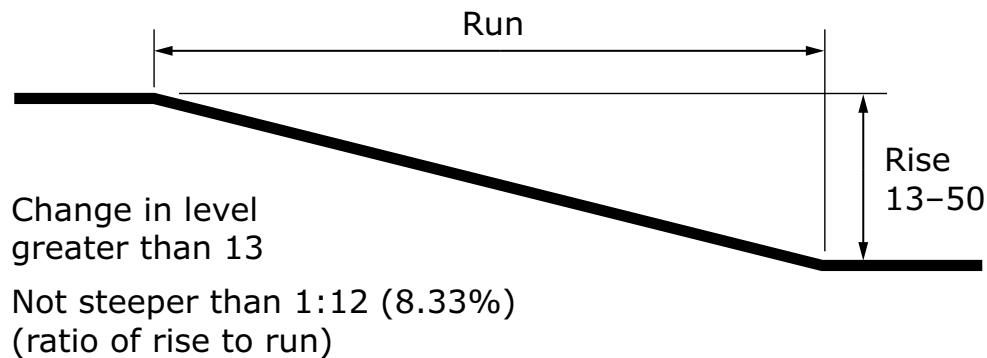

This figure shows a change in level of 13 to 50 mm with a slope not steeper than 1:12 (8.33%) ratio of rise to run.

Note: All dimensions are in mm.

Notes:

- 1) The site design should avoid changes in level between the main entrance and the exterior circulation route, parking, or passenger pick-up area.
- 2) Where changes in level are unavoidable, the area should be graded and designed to provide a gradual slope so as not to exceed a ratio of 1:20 (5%) over an extended distance.

4.6.4 Gratings and floor vents

Where there are gratings along an exterior route or floor vents along an interior path of travel, the gratings or vents shall

- a) be located on the outside edges or along walls of the accessible path of travel on the interior;
- b) be located outside of the accessible path of travel except where required for drainage along the exterior;
- c) have no opening that will permit the passage of a sphere more than 13 mm in diameter; and
- d) be placed so that the long dimension of the opening is perpendicular to the primary direction of travel.

4.7 Headroom and protruding objects

4.7.1 Headroom

Headroom clearances along a path of travel shall be not less than

- a) 2030 mm for doorways; and
- b) 2100 mm in all other spaces [see Figures [9 a\)](#) and [9 c\)](#)].

Note: Headroom clearances less than those addressed in Clause [4.7.1](#) and located outside the path of travel can be mitigated or made cane-detectable by adding a barrier or design feature with its leading edge at or below 685 mm from the floor, at the flexibility of the homeowner [see Figures [9 a\)](#) to [9 c\)](#)].

Figure 9 a)
Obstructions and protrusions – Less than 100 mm
from wall

(See Clauses [4.7.1](#) and [4.7.2](#).)

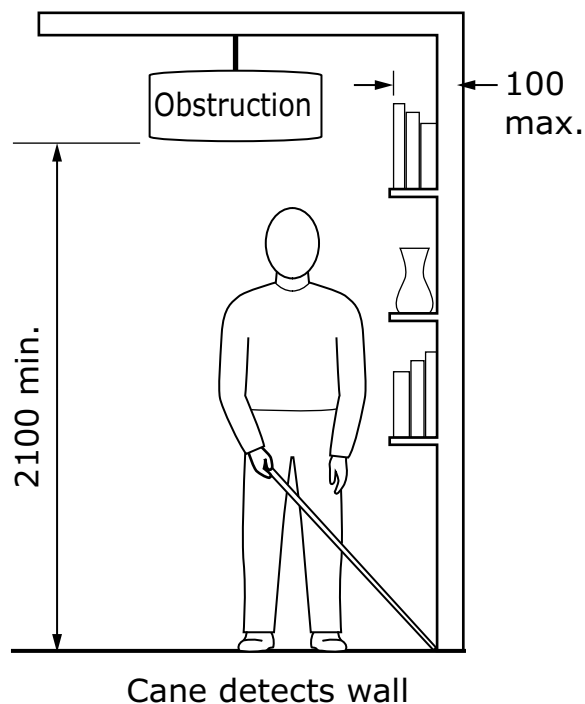

This figure shows a person standing under a light with 2100 mm headroom clearance from the floor. The person also has a cane, which is not contacting a shelf protruding from the wall; a maximum protrusion of 100 mm is noted for this type of obstruction.

Note: All dimensions are in mm.

Figure 9 b)
**Obstructions and protrusions – Greater than
100 mm from wall**

(See Clauses [4.7.1](#) and [4.7.2](#).)

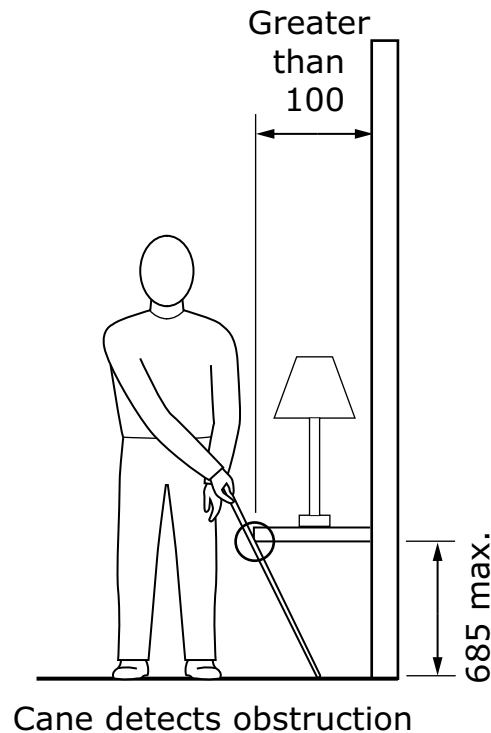

This figure shows a shelf that is protruding greater than 100 mm from the wall and is a maximum of 685 mm from the ground. This obstruction is detected by the person with a cane standing beside it.

Note: All dimensions are in mm.

Figure 9 c) Obstructions and protrusions – Minimum bulkhead height

(See Clauses [4.7.1](#) and [4.7.2](#).)

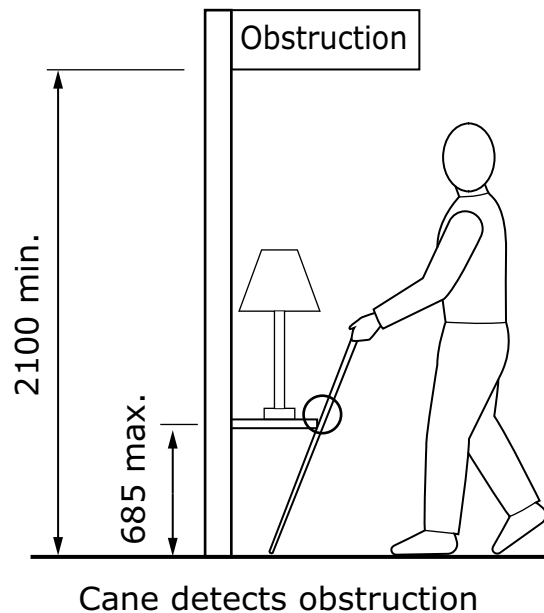

This figure shows a person with a cane detecting an obstruction a maximum of 685 mm from the ground. A minimum bulkhead height of 2100 mm is listed for bulkheads that are outside of the cane's detection.

Note: All dimensions are in mm.

4.7.2 Protruding objects

Protruding objects shall not create a hazard or reduce accessibility in the room or hallway. Objects protruding more than 100 mm from the walls, columns, or freestanding supports shall either

a) be cane-detectable at or below 685 mm from the floor; or

b) have their undersides at a height at least 2100 mm from the floor [see Figures [9 a\)](#) to [9 c\)](#)].

Notes:

- 1) Posts, columns, or walls that are angled to the vertical are potentially not detectable by a person with low or no vision and should be planned accordingly.
- 2) Examples of protruding obstructions include ductwork or the underside of stairways (see Figure [10](#)).
- 3) Recessing an object avoids creating a protrusion hazard.

Figure 10
Overhead obstructions
(See Clause [4.7.2.](#))

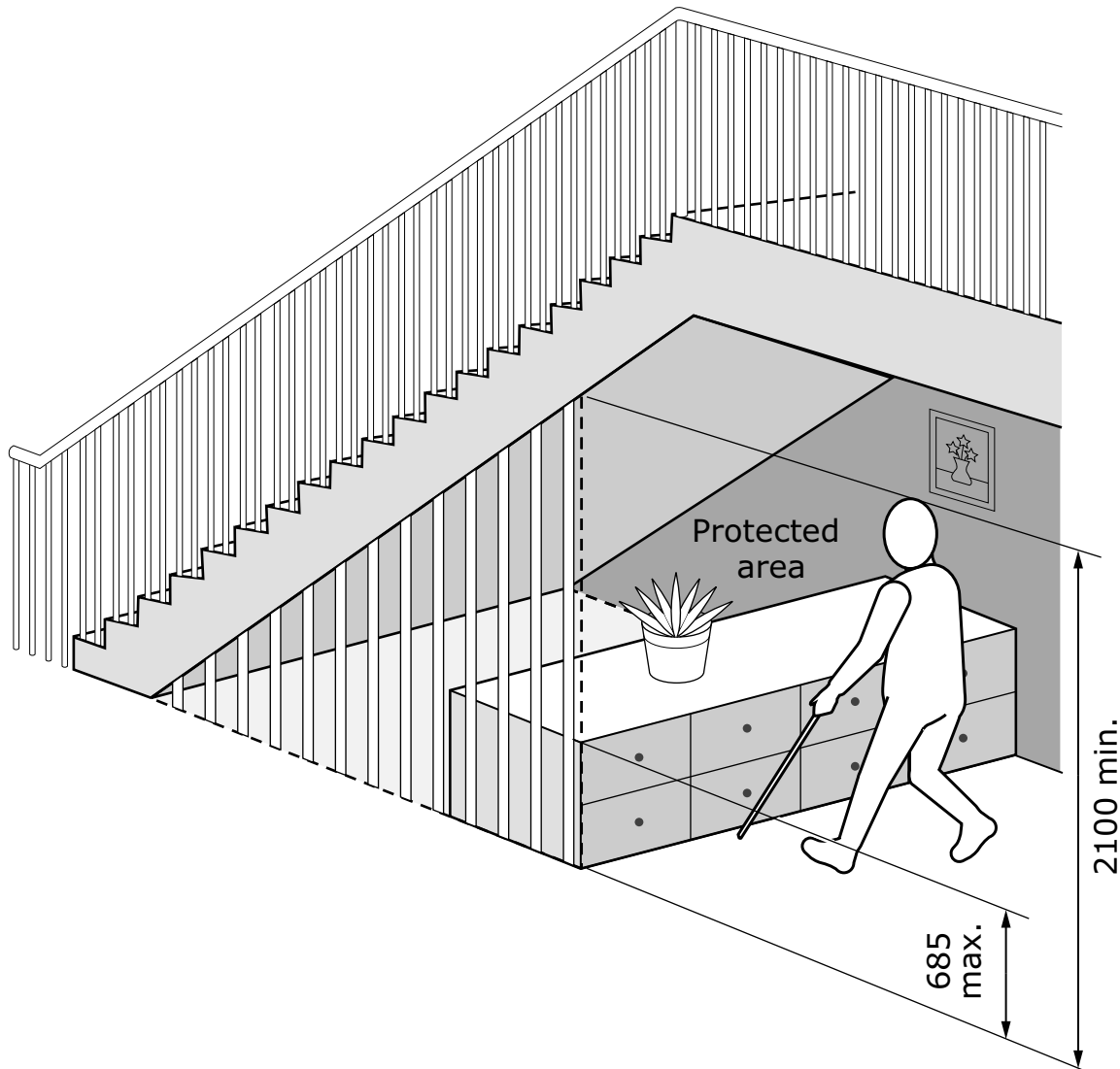

This figure depicts a protected space related to overhead hazards. It shows a man approaching the underside of a staircase. A protected area is noted under the staircase where the overhead clearance is less than 2100 mm. A barrier with a height exceeding 685 mm is placed on either side of the protected area, and a shelf prevents access to the protected area from the front.

Note: All dimensions are in mm.

4.8 Illumination (lighting)

4.8.1 General

4.8.1.1 General (ambient) illumination

General (ambient) illumination within an accessible dwelling shall be designed such that all spaces leading up to, leading into, and located within the dwelling are capable of being illuminated in their entirety to at least 50 lx at the floor level. Rooms should have built-in lighting in accordance with the minimum values outlined in Table [3](#).

Notes:

- 1) General (ambient) illumination means lighting intended to fully illuminate a room.
- 2) To improve the well-being of individuals in their homes, having the ability for each room and space within a dwelling to be fully illuminated offers meaningful opportunities for residents.
- 3) Lighting levels can be controlled via dimmer switches to suit individual preferences.
- 4) For those that need additional light, task lighting can supplement the main lighting.

4.8.1.2 Distribution

Illumination should provide uniform distribution throughout rooms and spaces.

4.8.2 Task lighting

Where provided, task lighting should be appropriate to the task (i.e., skirted or low profile), to avoid light shining directly into the user's face unless intended.

4.8.3 Hardwiring

Regardless of whether they are linked to a smart home system, light switches and their fixtures shall be hardwired and comply with Clause [4.5](#).

Table 3
Minimum lighting levels for residential spaces
 (See Clause [4.8.1.1.](#))

The table presents minimum lighting levels for residential spaces, listed by room and task.

Room	General/ ambient	Task
Kitchen	300 lx	Countertop, sink: 750 lx
Bedroom (adult)	100 to 300 lx	Desk, reading, table: 500 lx
Bedroom (child)	500 lx	Desk, reading, table: 800 lx
Bathroom	300 lx	Shave, makeup: 300 to 700 lx
Living room/den	300 lx	Reading 500 lx
Family room/ home theatre	300 lx (TV viewing 150 lx)	Reading, table: 500 lx
Laundry/utility	200 lx	Countertop, equipment: 300 lx
Dining room	200 lx	
Hall, landing/ stairway	100 to 500 lx	
Home office	500 lx	Desk, table: 800 lx
Garage	500 lx	Table, bench: 750 lx

(Continued)

Table 3 (Concluded)

Room	General/ ambient	Task
Workshop	800 lx	Bench, equipment: 1100 lx
Exterior (patios, balconies, decks, walkways, etc.)	50 lx	

Notes:

- 1) Types of fixtures that can be used for indoor lighting include but are not limited to
 - a) chandeliers or other ceiling-mounted fixtures;
 - b) wall-mounted fixtures;
 - c) traditional recessed fixtures (e.g., pot lights) and/or LED downlights;
 - d) track lights;
 - e) floor lamps; and
 - f) table lamps.
- 2) Types of fixtures for task lighting include but are not limited to
 - a) directional gimbal recessed fixtures or downlights;
 - b) pendant lightings;
 - c) slim line bar and under cabinet lights;
 - d) tape and extrusion lights; and
 - e) portable or desk lamps.

4.9 Windows

Where provided, at least one window per room shall

- a) if operable, comply with Clause [4.5](#); and
- b) have its lower edge (sill) not higher than 750 mm from the

finished floor (except in a bathroom that complies with Clause [5.9](#)).

Notes:

- 1) Windows providing a view of the outdoors should be installed with a lowered sill height for people who are of shorter stature or who might use an assistive mobility device. This provision does not eliminate the ability to also provide clerestory or skylight-style windows intended to draw light into the home.
- 2) Where a window is operable, it should be located such that it is possible for individuals with limited dexterity to approach the window without obstruction and open it easily.

5 Specific design elements

5.1 General

This Clause applies to the specific design elements leading up to and within the accessible dwelling unit.

Note: This Clause identifies key structural and spatial elements that are critical to the design phase of an accessible dwelling and can also have meaningful impact on accessible dwelling alterations. Minimum provisions for each design element have been outlined, and some Clauses include recommendations for enhanced accessibility features within their Notes for those who might wish to exceed the minimum requirements.

5.2 Exterior route and landscaping

5.2.1 Exterior route

An exterior route serving an accessible dwelling shall

- a) comply with Clauses [4.4.1](#), [4.6](#), and [4.7](#);
- b) have a running slope not steeper than a ratio of 1:20 (5%), unless designed as a ramp (see Clause [5.5](#));
- c) have a cross slope not greater than 1:50 (2%); and

- d) where there is a change in level or drop-off adjacent to the accessible path of travel, have side protection as follows:
- include no drop-off or a slope leading from the edge not steeper than 1:20;
 - if the vertical drop is between 75 and 600 mm deep, have edge protection with a minimum height of 100 mm [see Figure 11 a)]; or
 - if the vertical drop is greater than 600 mm, a handrail complying with Clause 5.5.8 Items a) to e) [see Figure 11 b)].

Figure 11 a)
Side protection adjacent to the accessible path of travel – Less than 600 mm vertical drop
(See Clause 5.2.1.)

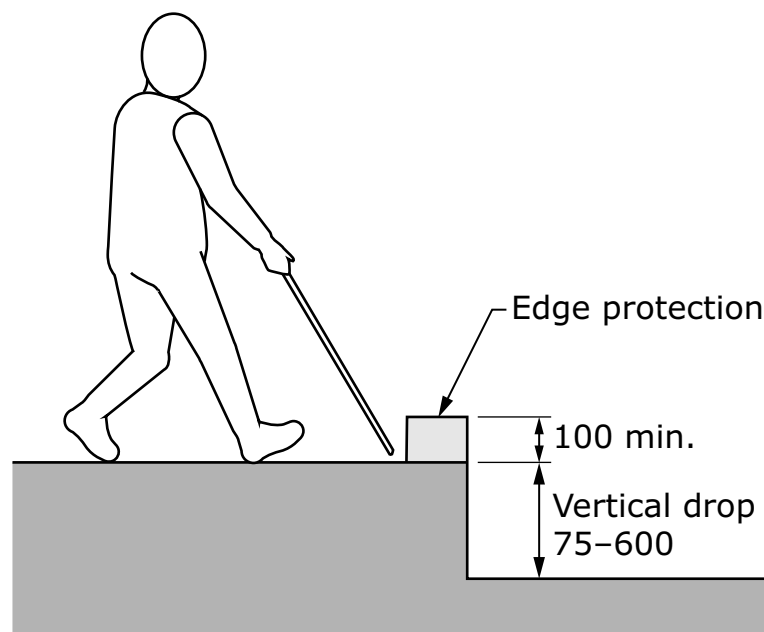

This figure depicts a person on an accessible path of travel with a 75 to 600 mm vertical drop next to the path. A min 100 mm high edge protection is depicted on the side of the path.

Note: All dimensions are in mm.

Figure 11 b)
Side protection adjacent to the accessible path of travel – More than 600 mm vertical drop
(See Clause [5.2.1.](#))

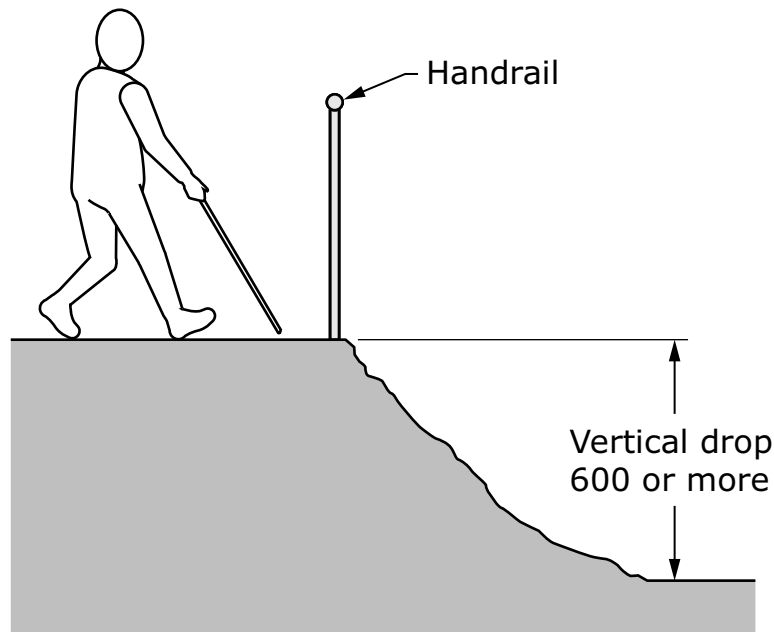

This figure depicts a person on an accessible path of travel with a greater than 600 mm vertical drop next to the path. A handrail is depicted on the side of the path.

Note: All dimensions are in mm.

5.2.2 Landscaping

Where there is landscaping, it shall not obstruct, overflow, or fall onto the accessible exterior path of travel.

Notes:

- 1) Firm and slip-resistant surfaces that can be used for accessible exterior pedestrian routes include asphalt, concrete, or coated lumber (with the planks running perpendicular to the direction of travel). Irregular surfaces such as cobblestones, pavers, and exposed aggregate paving can be difficult to traverse.
- 2) Consider materials that support permeation and drainage to limit potential ice formation and buildup.

- 3) Exterior paths of travel can benefit from embedded heating elements that help mitigate the need for snow clearing in winter months and prevent ice buildup.
- 4) Reducing thresholds and maintaining smooth and level transitions between different surfaces, or where a ground surface meets a garage or doorway, can reduce trip hazards and promote improved manoeuvrability into and out of the dwelling.
- 5) Landscaping should benefit the user by being designed to provide contrast for the designated path of travel while also taking into consideration improved sightlines, reduction in overgrowth along paths of travel, and catering to low maintenance.
- 6) Properly maintain accessible paths of travel and spaces. For example, since some paving materials can settle or heave in time, they can become a significant pedestrian barrier or hazard.

5.3 Parking space

5.3.1 General

An accessible dwelling provided with its own parking shall

- a) be served by an accessible path of travel complying with Clause [5.2](#) from the parking space up to the main entrance and into the dwelling from the garage, where provided;
- b) where a driveway is provided, the driveway shall be designed to accommodate at least one accessible-sized parking space, complying with Clause [5.3.2](#); and
- c) where there is a garage, the garage shall be designed to accommodate at least one accessible-sized parking space, complying with Clause [5.3.2](#).

Notes:

- 1) It is beneficial to place the parking space(s) in a convenient location that minimizes the distance travelled between the parking space(s) and entrances into the home.
- 2) Covered parking spaces should be provided, since they offer protection against adverse weather and eliminate the need to clear snow and ice.

- 3) Accessible signage is not required for a single-family home; however, signage requirements would apply for a complex of homes (e.g., townhouses, apartments) that share a common parking area (see CSA/ASC B651).
- 4) Pedestrian routes that border parking areas should be designed so that parked cars do not encroach on the clear width.
- 5) An automated power garage door opener allows for operating the garage door without exiting the vehicle.

5.3.2 Area allowances

An accessible parking space (see Figure [12](#)) shall be at least

- a) 4600 mm wide by 6600 mm long for side access; or
- b) 2600 mm wide by 8600 mm long for rear access.

Notes:

- 1) Accessible parking spaces permit an adjacent side access aisle at least 2000 mm wide, an adjacent rear access aisle at least 2000 mm long by 4600 mm wide, or a combination thereof.
- 2) Examples of types of facilities providing parking can include
 - a) exterior (or interior where provided) driveways;
 - b) carports (attached to or detached from the dwelling);
 - c) garages (attached to or detached from the dwelling); and
 - d) at-grade or underground parkades.

Figure 12
Accessible parking space
(See Clause [5.3.2.](#))

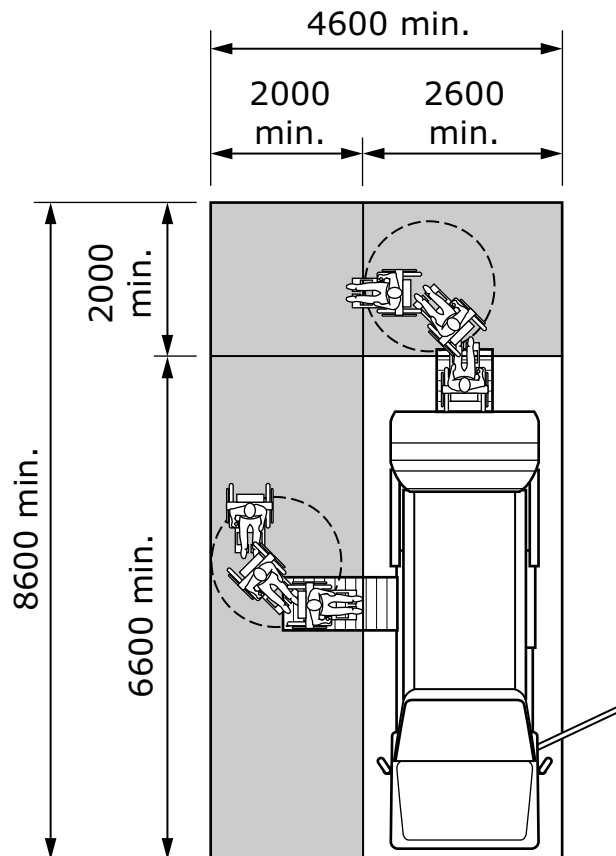

This figure depicts a car parked in an accessible parking space with a 2000 mm clearance area to the left and back of the vehicle. The accessible parking space dimensions are 4600 mm by 8600 mm.

Note: All dimensions are in mm.

5.3.3 Garages

Where provided, garages shall

- a) have illumination on a motion sensor;
- b) where provided, have controls (e.g., automatic door opener, electric vehicle charger) that
 - i) comply with Clause [4.5](#); and

- ii) require a force of not more than 65 N to stop door movement, except when the door is equipped with a safety sensor that automatically stops the door if there is an obstruction in its path; and
- c) have a (vehicle) garage door clear opening at least 2440 mm wide by 2440 mm high (see Figure [13](#)).

Notes:

- 1) If there is an electric vehicle charger, avoid having the cord obstruct the accessible path of travel.
- 2) Garage layouts can be planned for additional storage beyond the accessible parking space.

5.3.4 Car ports

Car ports shall

- a) comply with Clause [5.3.2](#); and
- b) have a clear height at the vehicle entrance of at least 2440 mm.

Figure 13
Accessible garage
 (See Clause [5.3.3.](#))

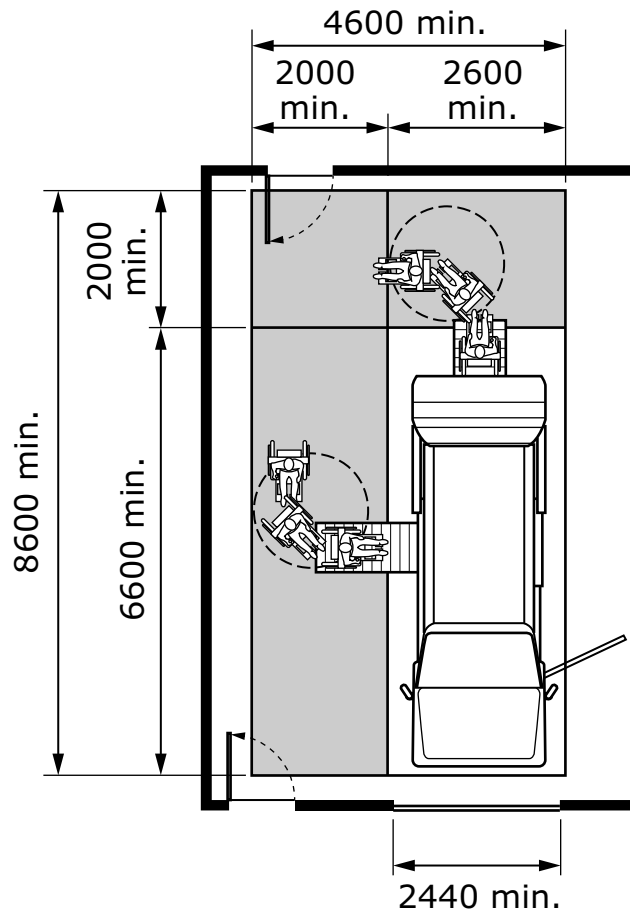

This figure depicts a car parked in an accessible garage. The car occupies a space of 2600 mm by 6600 mm inside the garage, maintaining a 2000 mm clearance area to the left and in back of the parked car.

Note: All dimensions are in mm.

Notes:

- 1) Minimum interior dimensions of 6100 mm wide by 9150 mm long can allow manoeuvring around most vehicles.
- 2) Where environmentally sustainable and in situations where the garage is detached from the dwelling, consider installing heat tracing along the accessible path of travel between the garage and the dwelling.

- 3) A larger double-car garage door (4875 mm wide by 3000 mm high) will provide flexibility for drive-in and back-in options, and permit alternate access aisle configuration.

5.3.5 Height allowances

The clearance from the pavement to the underside of any ceiling structure or hanging object shall be at least 2750 mm (3000 mm for short-term accommodations)

- a) along the vehicular route; and
- b) at the accessible parking space (see Figure [14](#)).

Figure 14
Accessible garage
(See Clause [5.3.5](#).)

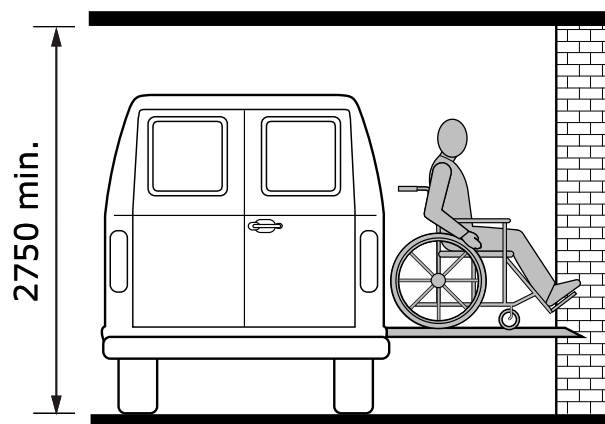

This figure depicts the minimum 2750 mm height clearance required in an accessible garage. Note this minimum height clearance is 3000 mm for short-term accommodations.

Note: All dimensions are in mm.

5.4 Exterior amenities

Exterior amenities immediately serving the accessible dwelling (e.g., patios, balconies, decks) shall be accessible in accordance with the guidelines of this Standard. Refer to

CSA/ASC B651 for requirements for short-term accommodation.

Notes:

- 1) Refer to CSA/ASC B651 for the design of shared amenities within a residential development.
- 2) If differences in height are unavoidable, ramps for small level changes may be provided.
- 3) Covered patios, balconies, or deck entrances benefit from shelter to protect against adverse weather conditions.

5.5 Ramps

Note: Ramps serving short-term or multi-unit residential accommodations not immediately serving the dwelling are exempt from complying with the requirements in this Clause. See CSA/ASC B651 for more information.

5.5.1 Running slope and length

Where provided, a ramp shall have

- a) a running slope with the ratio between 1:15 (6.66%) and 1:20 (5%) [see Figures [15 a\)](#) and [15 b\)](#)]; and
- b) a distance between level landings not greater than 9000 mm.

Figure 15 a)
Running slope – 1:15
 (See Clause [5.5.1.](#))

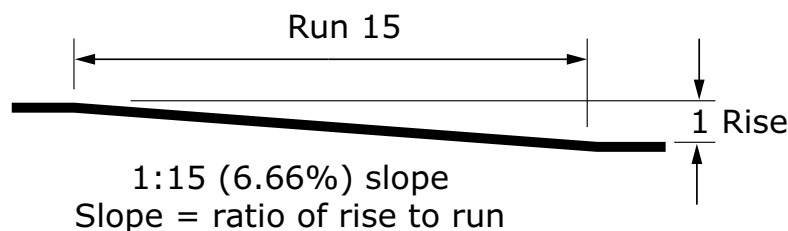

This figure shows a run with a slope of 1:15 (6.66%).

Note: All dimensions are in mm.

Figure 15 b)
Running slope – 1:20
 (See Clause [5.5.1.](#))

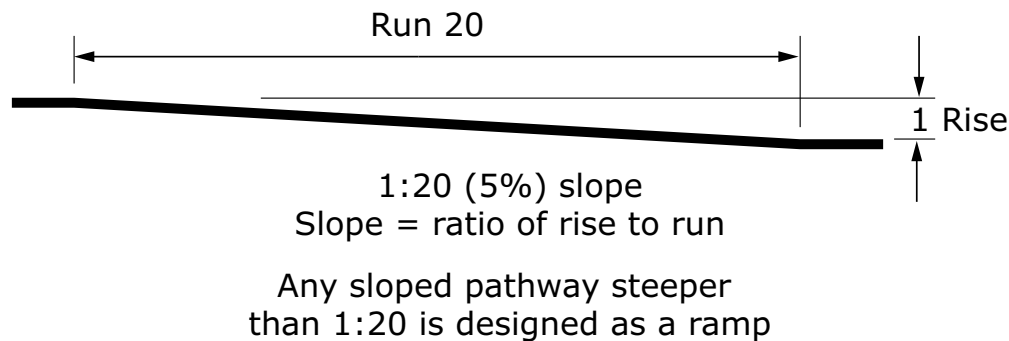

This figure shows a run with a slope of 1:20 (5%).

Note: All dimensions are in mm.

Notes:

- 1) The running slope of the ramp is the ratio of the change in level (vertical rise) to its horizontal length (run). The more gradual the slope of the ramp (i.e., the less steep it is), the more easily people can use it without assistance. Therefore, slopes with gradients of less than 5% benefit the largest number of people.
- 2) Ramps with shorter distances between landings can be easier to navigate.
- 3) Routes with a gradual slope that is less steep than 1:20 (5%) do not have to follow the specifications for ramps; however, people still benefit from sloped pathways designed similar to that of ramps when level landings at regular intervals and handrails are provided.
- 4) Some people find using steps easier and safer than a ramp; therefore, both stairs and a ramp can be provided in any one location.
- 5) In circumstances where a ramp is under consideration to navigate a major vertical rise resulting in several ramp segments and landings, other design options, such as a lift or redesign of the exterior plain, can be considered.
- 6) Avoid curved ramps where possible.

5.5.2 Cross slope

The cross slope of the ramp surface shall not be greater than 1:50 (2%).

5.5.3 Width

The clear width of a ramp shall be at least 1200 mm, except for home alterations where a minimum clear width of 1000 mm is acceptable.

5.5.4 Landings

A level landing shall

- a) be provided at the top and bottom of each ramp segment;
- b) be provided at all changes in direction along the ramp;
- c) be at least 1800 mm long by 1800 mm wide at the top and bottom or at a change in direction;
- d) have intermediate landings with a length not less than 1800 mm and be as wide as the ramp serving it, but not less than 1200 mm, in the case of a linear ramp; and
- e) where it meets a slope change, have a 50 ± 10 mm-wide luminance (colour) contrasted and slip-resistant strip equal to the width of the ramp [see Figure [16 a](#)].

Note: Doorways at landings still require sufficient manoeuvring area at the latch edge of the door [see Figure [16 b](#)].

Figure 16 a)
Ramps — Intermediate landing with a sharp turn
 (See Clause [5.5.4.](#))

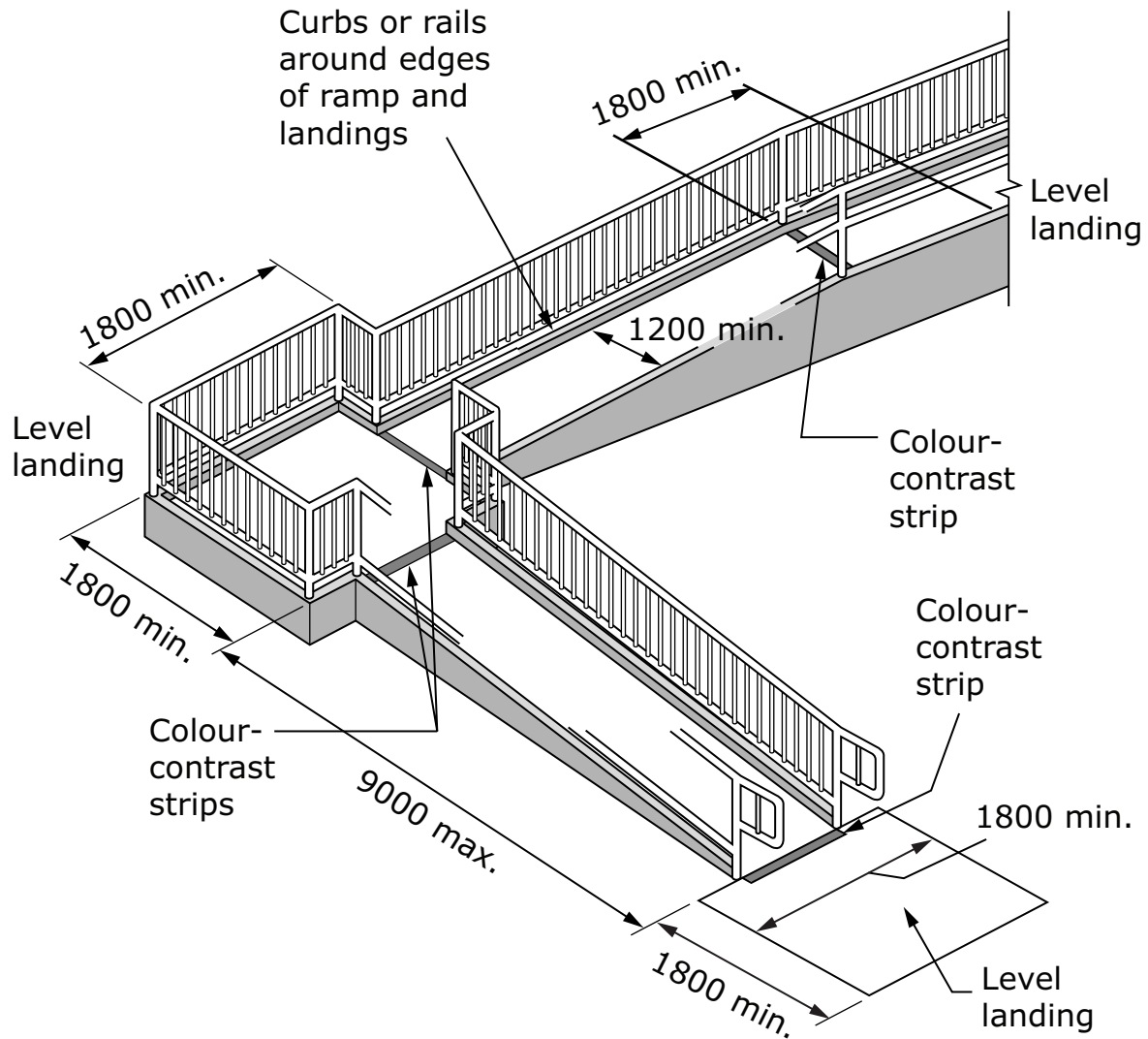

Figure 16 a) (Concluded)

This figure shows dimensions for intermediate landings for ramps that have changes in direction. It depicts an entrance area onto the ramp that is 1800 mm deep by 1800 mm long. The ramp leading to the lower-level landing is a maximum 9000 mm long. The level landing at the turn is square-shaped with a minimum length and width of 1800 mm. The ramp width is denoted as a minimum of 1200 mm and an 1800 mm long level landing at the top of the ramp is displayed. The graphic indicates a luminance (colour) contrast strip at each major change in slope along the length of the ramp.

Notes:

- 1) Handrails have been partially omitted for clarity.
- 2) All dimensions are in mm.

Figure 16 b)
Ramps – Doorway at landing
 (See Clause [5.5.4.](#))

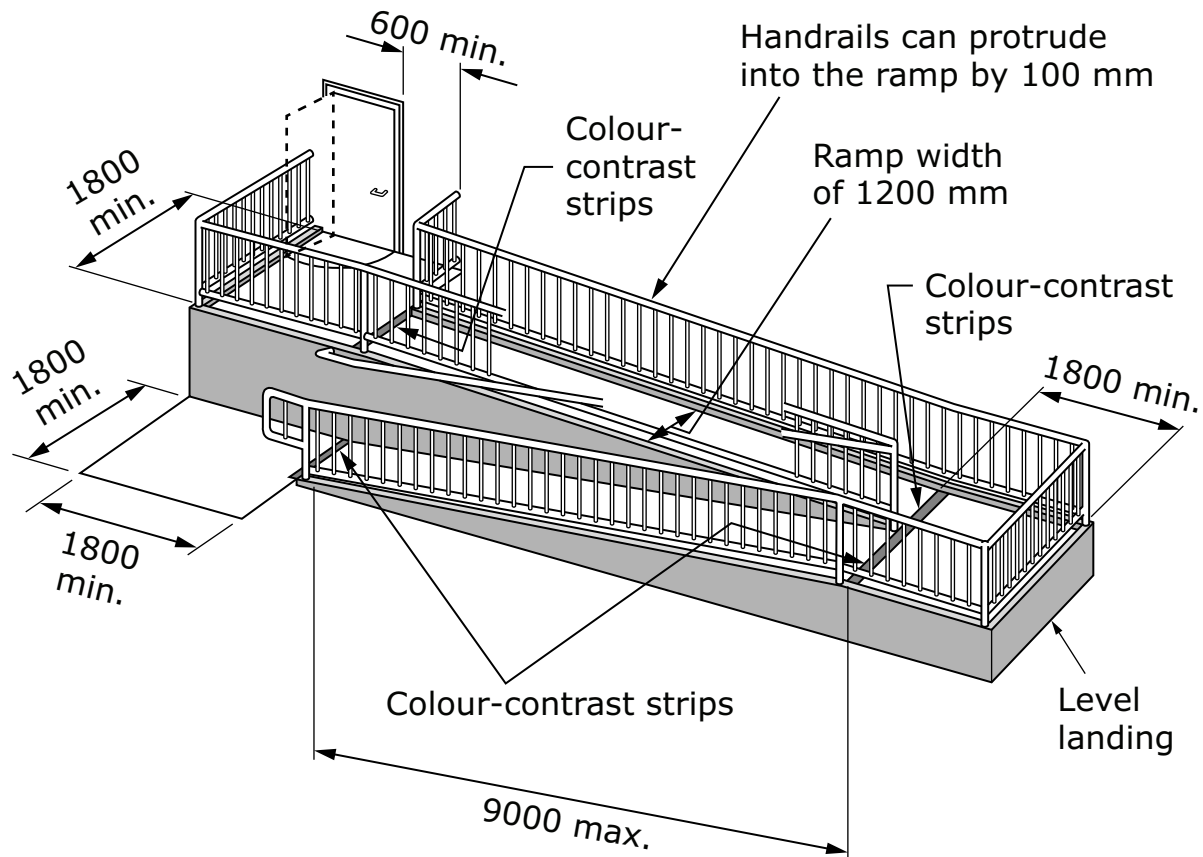

This figure shows a ramp approaching an out-swinging door from the latch side. The graphic shows the door frame positioned a minimum of 600 mm from the mounted handrail. There is a luminance (colour) contrast strip adjacent to the doorway to indicate the change in slope heading down the ramp. The length of the landing in front of the doorway is 1800 mm wide by 1800 mm deep. The ramp width is denoted as a minimum of 1200 mm.

Notes:

- 1) Handrails have been partially omitted for clarity.
- 2) All dimensions are in mm.

5.5.5 Surfaces

Surfaces of ramps and landings shall comply with Clause [4.6.1](#).

5.5.6 Edge protection

On ramps and landings that are not at grade or adjacent to a wall, the following edge protection shall be provided:

- a) a curb with a minimum height of 100 mm [see Figure [17 a\)](#)];
or
- b) a raised barrier or rail with its lower edge not more than 100 mm from the ramp or landing surface [see Figures [17 b\)](#) and [17 c\)](#)].

Figure 17 a)
Edge protection – Curb
(See Clause [5.5.6](#).)

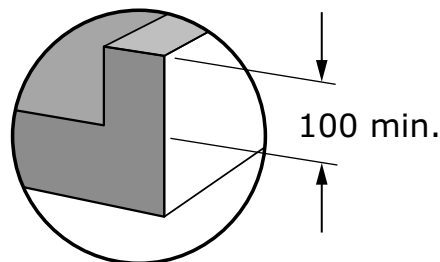

This figure shows edge protection provided by a curb with a minimum height of 100 mm.

Note: All dimensions are in mm.

Figure 17 b)
Edge protection – Raised barrier
(See Clause [5.5.6.](#))

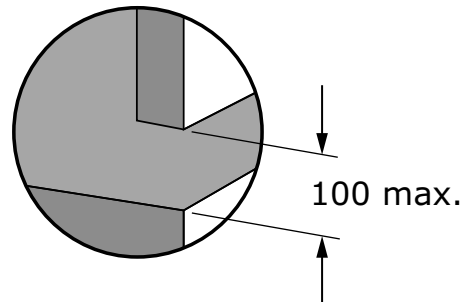

This figure shows edge protection through a raised barrier with its lower edge not more than 100 mm from the ramp or landing surface.

Note: All dimensions are in mm.

Figure 17 c)
Edge protection – Rail
(See Clause [5.5.6.](#))

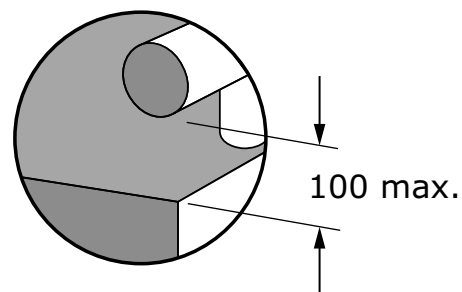

This figure shows another example of edge protection through a rail with its lower edge not more than 100 mm from the edge.

Note: All dimensions are in mm.

Notes:

- 1) Ramp edge protection is provided to prevent wheels or walking aids from moving off the ramp surface.
- 2) Edge protection is meant to complement the safety aspects of handrails (see Clause [5.5.8.](#)).

- 3) Depending on the environment, solid curb edge protection can impede the easy removal of debris or snow.

5.5.7 Illumination

When illuminated, the surface level of a ramp and landings shall be illuminated to at least

- a) 100 lx for the interior installation; and
- b) 50 lx for the exterior installation.

5.5.8 Handrails

Ramps shall have handrails on both sides that

- a) resist a force of at least 1.3 kN applied in any direction;
- b) have a graspable cross-section that is either
 - i) circular with an outside diameter of 30 to 40 mm [see Figure [18 a](#))]; or
 - ii) elliptical with an outside perimeter between 100 and 125 mm, with the largest cross-sectional dimension not more than 45 mm [see Figure [18 b](#))];
- c) are free of any sharp or abrasive elements;
- d) have a continuous gripping surface, without interruption by newel posts or other construction elements or obstructions that interrupt a handhold;
- e) have a clear space between the handrail and the wall, and underneath the handrail, as follows:
 - i) at least 50 mm for a smooth wall surface; and
 - ii) at least 60 mm for a rough wall surface;
- f) are continuous on the ramp and around landings;
- g) are luminance (colour) contrasted with their surroundings;
- h) maintain a minimum clear width of 1000 mm between the rails;
- i) have a height between 860 and 920 mm, measured from the ramp surface to the top of the rail; and

- j) have horizontal extensions beyond the top and bottom of the ramp
 - i) at least 300 mm long; and
 - ii) that are returned to the post, floor or ground, or wall, and, if returning to the post, must be cane-detectable within 685 mm from the floor or ground (see Figure 19).

Notes:

- 1) Handrails should not terminate in a manner that could project into a path of travel or create a hazard.
- 2) A load of 1.3 kN is the equivalent of 136 kg.

Figure 18 a)
Ramp handrails
(See Clause 5.5.8.)

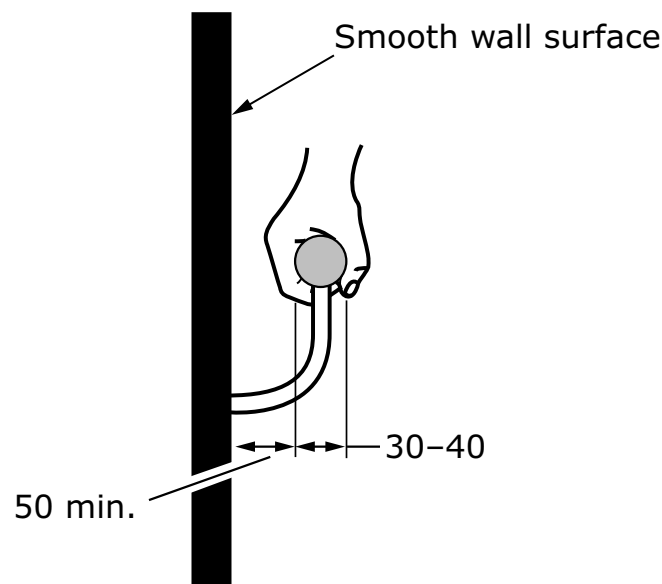

This figure depicts the dimensions for how far a graspable handrail should be from a mounted surface. In this example, the portion of the handrail that is mounted to the surface is a minimum 50 mm from the smooth wall surface, and the handrail itself is an additional 30 to 40 mm from the mounted portion of the handrail.

Note: All dimensions are in mm.

Figure 18 b)
Ramp handrails – Acceptable and unacceptable examples
(See Clause [5.5.8.](#))

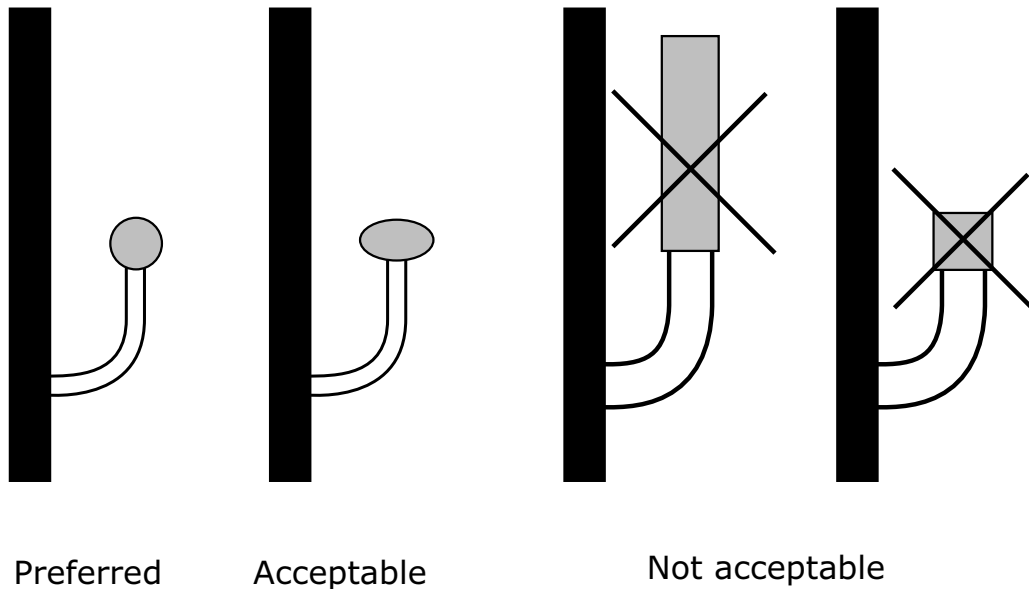

This figure shows examples of preferred, acceptable, and not acceptable handrail shapes. On the left side of the graphic, there is an image of a rounded handrail, the preferred handrail shape. Right beside the preferred handrail is an image of a slightly wider handrail shape that is still rounded and therefore deemed acceptable though not the preferred shape. On the far right is an image of two more examples of handrails deemed unacceptable due to their square and rectangular shapes.

Figure 19
Ramp handrail extensions – Handrail returns
 (See Clause [5.5.8.](#))

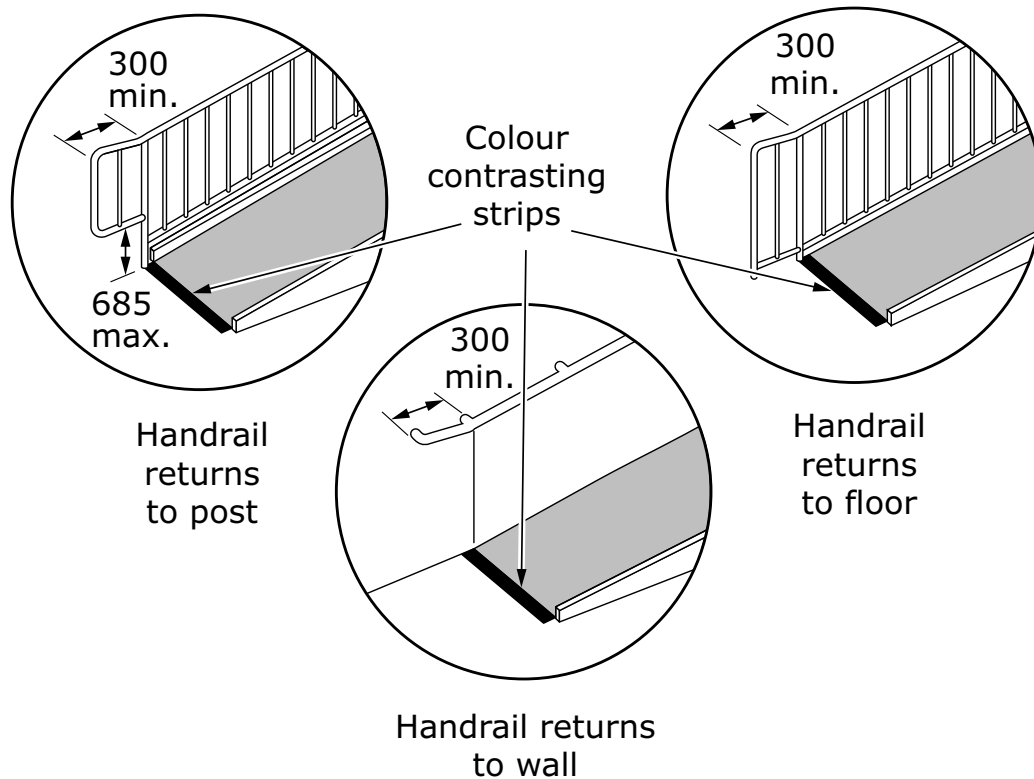

This figure shows three examples of ramp handrails. The first example shows a handrail that returns to a post. The second example shows a handrail that returns to the floor. The third example shows a handrail that returns to the wall. Each example shows the length of the handrail extension at a minimum of 300 mm from the end of the ramp, and the ramp end is marked by a luminance (colour) contrasting strip.

Notes:

- 1) Near handrail is omitted for clarity.
- 2) All dimensions are in mm.

5.6 Stairs

5.6.1 Treads and risers

A flight of stairs shall

- have uniform riser heights and tread depths;
- have risers not more than 180 mm;
- have runs not less than 280 mm deep, measured from riser to riser;
- have treads that are slip-resistant;
- have no open risers [see Figure [21 a](#)]; and
- be illuminated to at least 50 lx at the tread.

Note: In addition to luminance (colour) contrasted nosings, landings that luminance (colour) contrast to stairs can be beneficial for those with reduced vision [see Figure [20 b](#)].

Figure 20 a)
Stairs – Tread depth
(See Clause [5.6.2](#).)

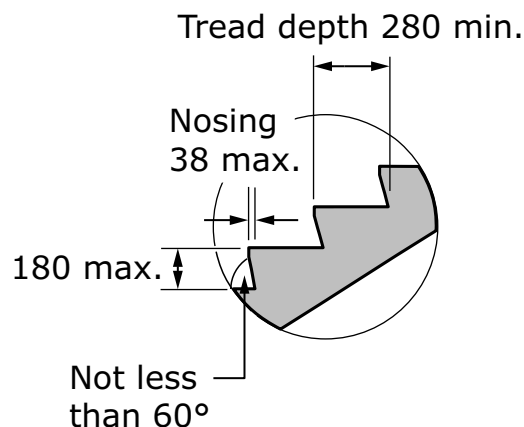

This figure shows stairs with a potential stair nosing design, where the projecting nosing is sloped to the riser at an angle greater than 60° to the horizontal with a maximum tread height of 180 mm, minimum tread depth of 280 mm, and maximum nosing depth of 38 mm.

Note: All dimensions are in mm.

Figure 20 b)
Stairs – Luminance (colour) contrasting strips

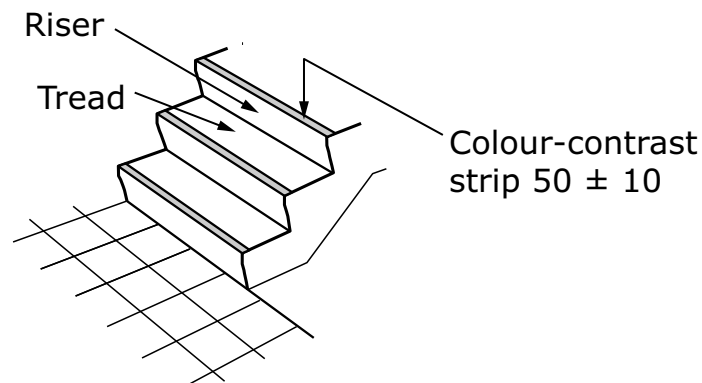

This figure shows luminance (colour) contrasting strips 50 ± 10 mm wide at the nosing of each stair tread.

Note: All dimensions are in mm.

Figure 20 c)
Stairs – Nosing
 (See Clause [5.6.2.](#))

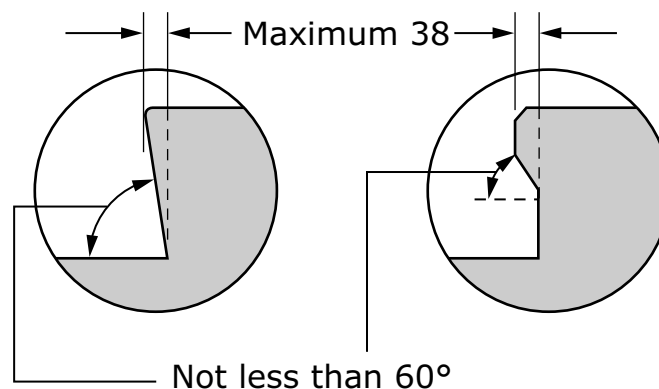

This figure shows two potential designs for the stair nosing, one with the entire stair riser sloped at a 60° angle and the other with the base of the stair nosing sloped at a 60° angle.

Note: All dimensions are in mm.

Figure 21 a)
Stairs – Open risers
(See Clause [5.6.1.](#))

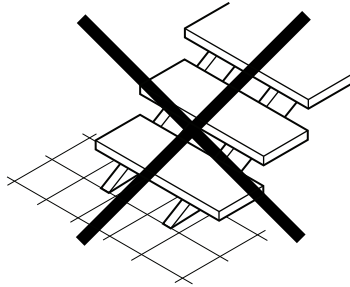

Open risers not acceptable

This figure shows that open risers are not acceptable.

Figure 21 b)
Stairs – Abrupt undersides
(See Clause [5.6.2.](#))

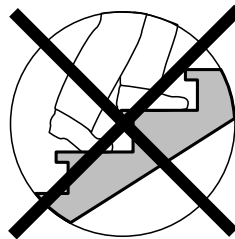

Risers with abrupt undersides
not acceptable

This figure shows that risers with abrupt undersides are not acceptable.

5.6.2 Nosing

The nosing shall

- project not more than 38 mm;
- where projecting, be sloped to the riser at an angle greater than 60° to the horizontal [see Figures [20 a\)](#) and [20 c\)](#)];
- have no abrupt undersides [see Figure [21 b\)](#)];

- d) have a radius of curvature at the leading edge of the tread not more than 13 mm; and
- e) have a horizontal strip 50 ± 10 mm deep that
 - i) is luminance (colour) contrasted with the tread and riser;
 - ii) is slip-resistant; and
 - iii) extends the full width of the tread.

5.6.3 Handrails

Stairs shall have handrails on both sides that

- a) comply with Clause [5.5.8](#) Items a), b), c), and e);
- b) be of uniform height, from 860 to 1070 mm, measured vertically from the leading edge of the tread to the top of the handrail [see Figure [22 b\)](#)];
- c) be continuous around landings less than 2100 mm in length except where the landing
 - i) is intersected by an alternative path of travel; or
 - ii) a door opens onto it;
- d) be continuous where located on the inside edge of the stairs [see Figure [22 a\)](#)]; and
- e) have horizontal extensions that
 - i) at the top of stairs, extend at least 300 mm parallel to the floor surface [see Figure [22 c\)](#)];
 - ii) at the bottom of the stairs, continue to slope for a distance equal to the depth of one tread and then extend horizontally for 300 mm parallel to the floor surface [see Figure [22 d\)](#)]; and
 - iii) return back to the post, floor, or wall [see Figures [22 c\)](#) and [22 d\)](#)].

Note: Supplementary handrails can be provided in addition to the required handrails.

Figure 22 a)
Stair handrails
 (See Clause [5.6.3.](#))

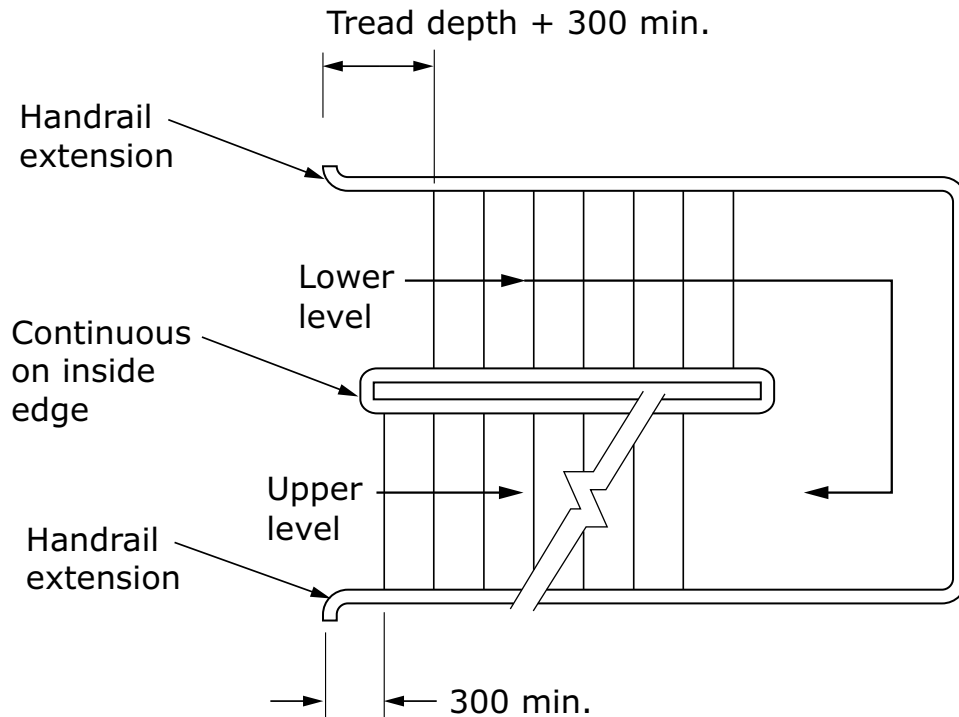

This figure indicates the handrail at the base of a staircase going in either direction (up or down) should extend a minimum of 300 mm.

Note: All dimensions are in mm.

Figure 22 b)
Continuous inside handrail at stairs
(See Clause [5.6.3.](#))

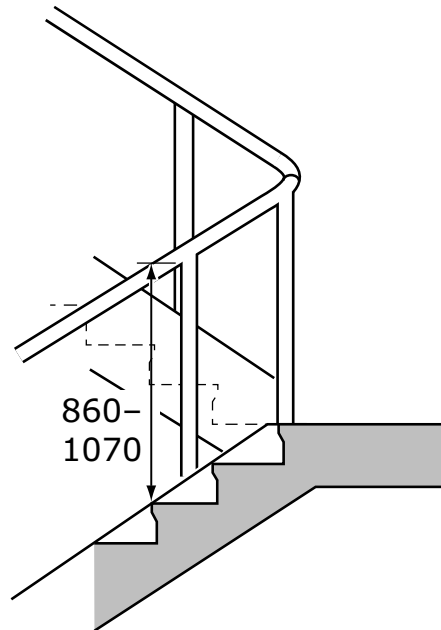

This figure demonstrates the requirement to have a continuous handrail on the inside edge of stairs. The height of the handrail is 860 to 1070 mm.

Note: All dimensions are in mm.

Figure 22 c)
Handrail extensions
(See Clause [5.6.3.](#))

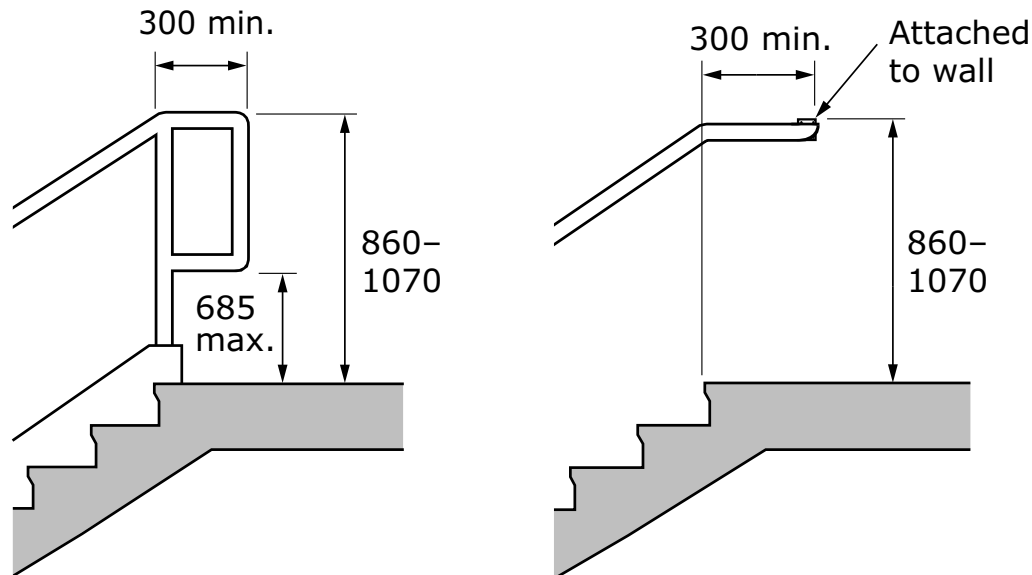

This figure demonstrates two examples of a handrail extension at the top of stairs that are parallel to the floor surface. The first graphic shows a looped handrail extension that is a minimum 300 mm in width. The height of the extension is shown to be 860 to 1070 mm from the ground, whereas the height of the extension handrail is a maximum of 685 mm above the ground. The second graphic shows a simple handrail extension that is mounted to the wall, with a minimum width of 300 mm. The height of the extension is shown to be 860 to 1070 mm from the ground.

Note: All dimensions are in mm.

Figure 22 d)
Stair handrails — Looped extension
 (See Clause [5.6.3.](#))

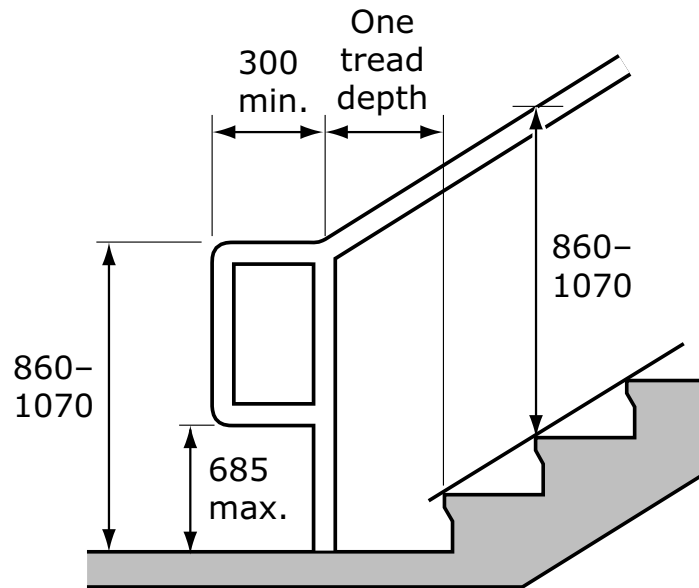

This figure demonstrates a looped handrail extension at the bottom of stairs that is parallel to the floor surface. The width of the extension is a minimum 300 mm, or the depth of one tread. The height of the extension is shown to be 860 to 1070 mm from the ground, and the height of the extension handrail is a maximum of 685 mm above the ground.

Note: All dimensions are in mm.

5.6.4 Exterior stairs

Exterior stairs shall

- a) be designed to avoid water accumulation; and
- b) have landings designed to drain water from their surfaces while not being steeper than a ratio of 1:50 (2%).

5.7 Doors and doorways

5.7.1 Opening width

The clear opening width of a doorway shall be at least 860 mm

- a) for swinging doors, when measured between the face of the door and the face of the stop when the door is in a 90° open position [see Figure 23 a)]; and
- b) for sliding doors, when measured between the edge of the open door and door frame [see Figure 23 b)].

Figure 23 a)
Clear opening width of doorway — Hinged doors
(See Clause 5.7.1.)

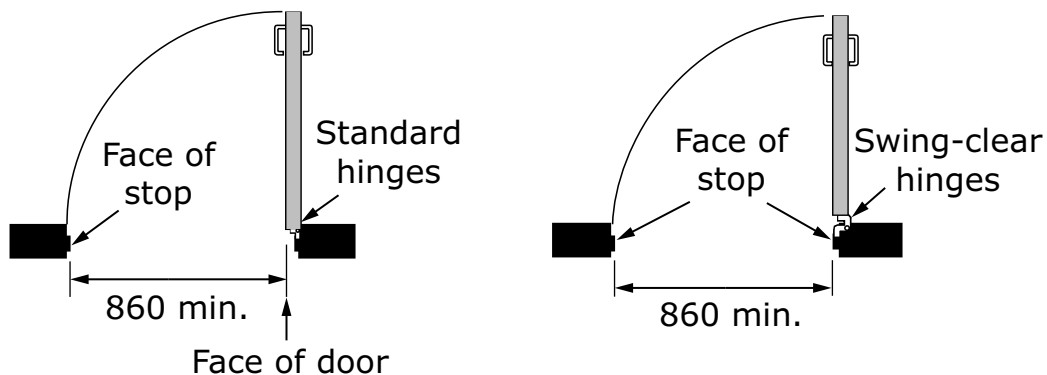

This figure shows a swinging door with standard hinges and an 860 mm opening width of a doorway between the face of stop and the face of the door that is open 90°. Also shown is a swinging door with swing-clear hinges and an 860 mm opening width of a doorway in between two stops for a door that is open 90°.

Note: All dimensions are in mm.

Figure 23 b)
Clear opening width of doorway — Sliding doors
 (See Clause [5.7.1.](#))

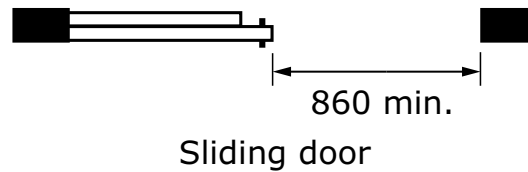

This figure shows an 860 mm opening width of a doorway for sliding doors with the clear opening width of the doorway between the edge of the open door and the door frame.

Note: All dimensions are in mm.

Notes:

- 1) Doors or door frames that are luminance (colour) contrasted with their surroundings allow people to locate doors more easily. The same principle applies to door hardware.
- 2) A 965 mm wide door (or larger) can achieve a minimum 860 mm clear width.
- 3) In existing dwellings, swing clear hinges can be used to increase the clear opening without enlarging the frame [see Figure [23 a\)](#)]. When open, such hinges move the door behind its frame, thereby increasing the clear opening width.

5.7.2 Manoeuvring area at doors

Note: Refer to CSA/ASC B651 for requirements for multi-unit residential accommodations with primary entrances not serving an immediate dwelling.

5.7.2.1 General

Doorways shall have a level, clear, and unobstructed manoeuvring area that extends for the full height of the door and is not less than

- a) 600 mm beyond the latch-side on the pull side (see Figure [24\)](#);

- b) 300 mm beyond the latch-side on the push side (see Figure [24](#));
- c) 300 mm on each side of a sliding door (see Figure [25](#)); and
- d) the width of the path of travel serving the door, but never less than 1200 mm for interior spaces and not less than 1500 mm for exterior spaces.

For short-term residential accommodations, the entrance immediately serving the dwelling shall have a landing with a level area at least 2100 by 2100 mm.

Notes:

- 1) At dwelling unit entrances, consider larger landings of at least 2250 by 2250 mm to accommodate larger mobility devices.
- 2) Maintaining a clear floor space off to the latch edge of the door on both sides provides a person who uses an assistive mobility device or service animal the ability to approach the door, open it, and remain clear of the door swing.

5.7.2.2 Power doors

If equipped with a power door operator, the level, clear, and unobstructed manoeuvring area shall comply with Clause [5.7.2.1](#) d) in regard to width.

Figure 24
Front approach at swinging door
(See Clause [5.7.2.1.](#))

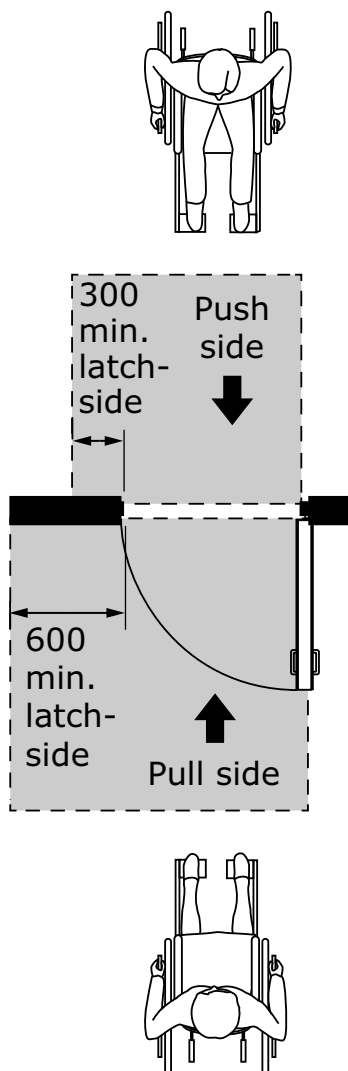

This figure shows the minimum required dimensions for assistive mobility device users to manoeuvre at swinging doors. It shows two people in assistive mobility devices approaching a door from opposite sides. There is a minimum 300 mm clear floor area beside the latch on the push side of the door, and a minimum 600 mm clear floor area beside the latch on the pull side of the door.

Note: All dimensions are in mm.

Figure 25
Approach at sliding door
 (See Clause [5.7.2.1.](#))

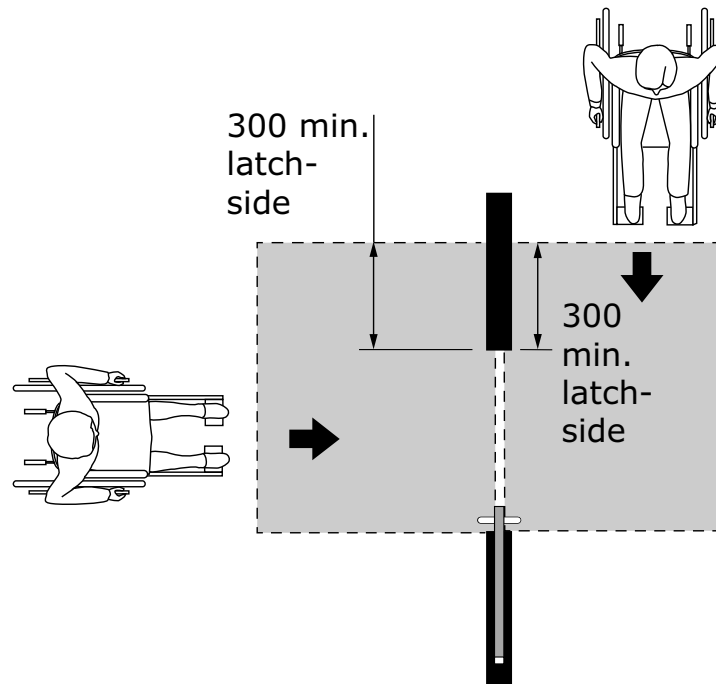

This figure depicts two people in assistive mobility devices approaching a sliding door from the front and side. When approaching a sliding door from the front or side, a minimum clear floor area of 300 mm beside the latch is shown.

Note: All dimensions are in mm.

5.7.3 Two doors in series

Where there are two doors in a series, the distance between the two doors shall be at least 1390 mm plus the width of any door swinging into the space (see Figure [26](#)).

Figure 26
Manoeuvring area at doors in series
(See Clause [5.7.3.](#))

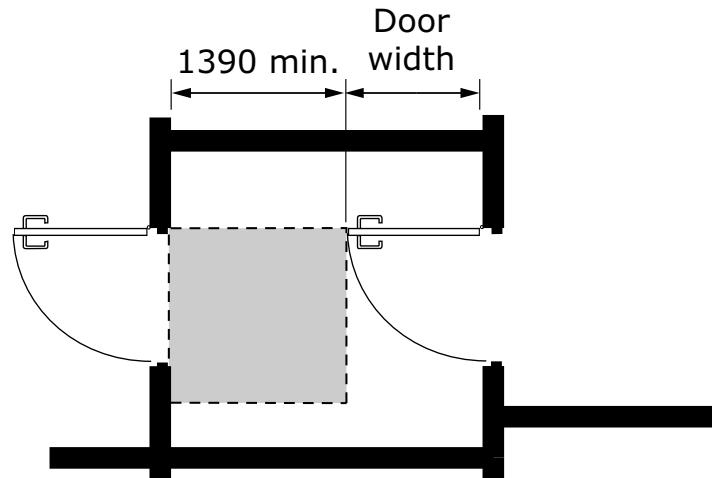

This figure shows the distance required between two outward swinging doors in a series. In the vestibule, a minimum clear floor area of 1390 mm plus the width of the door is depicted.

Note: All dimensions are in mm.

Notes:

- 1) In the Canadian climate, it is desirable to have a vestibule at the dwelling entrance.
- 2) To maximize ease and use of the space between two doors, consider increasing the distance or accommodating an 1800 mm turning circle.

5.7.4 Thresholds

Thresholds shall

- a) be not more than 13 mm high; and
- b) where over 6 mm high, be bevelled at a slope not steeper than a ratio of 1:2 (50%) [see Figures [8 a\)](#) and [8 b\)](#)].

5.7.5 Door hardware

5.7.5.1 Operating devices

Operating devices shall

- a) comply with Clause [4.5](#) for operating controls, except security hardware (e.g., key locks) which shall be exempt from Clause [4.5.5 a\)](#);
- b) be mounted between 900 and 1100 mm from the floor; and
- c) in all door cases (swinging, sliding, or other), be exposed and usable from both sides.

Notes:

- 1) Lever handles or other types of handles that can be operated with a closed fist are examples of accessible hardware that can be used on latched doors. U-shaped door levers [see Figures [27 a\)](#) and [27 b\)](#)] reduce the risk of catching on clothing or injury from the exposed lever end. Knob handles and thumb-latch handles are not appropriate because they require tight grasping and fine finger control. Push-pull mechanisms are preferred.
- 2) Consider installing kickplates to protect doors and maintain their longevity.
- 3) Where D-shaped handles are used, allow for sufficient clearance (35 to 45 mm minimum) in between the door and the handle to support grasping or use by someone with a closed fist.

Figure 27 a)
Handles
(See Clause [5.7.5.1.](#))

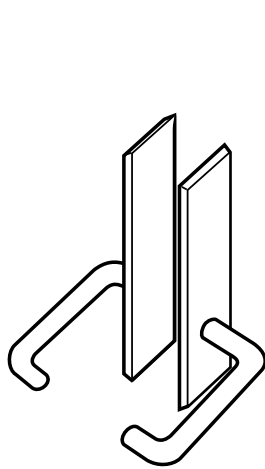

Lever handles

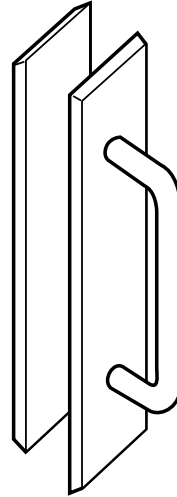

Push plate/door pull

This figure shows two examples of lever and push plate/door pull handles that can be operated with a closed fist.

Figure 27 b)
Handles – Unacceptable examples
(See Clause [5.7.5.1.](#))

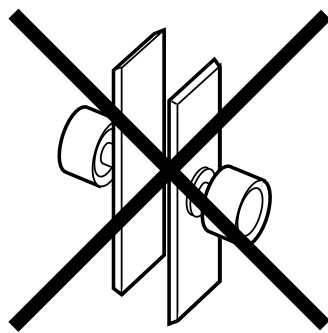

Knob handles

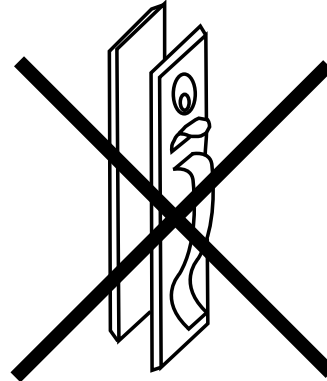

Thumb-latch handles

This figure shows two examples of knob handles and thumb-latch handles that cannot be opened with a closed fist.

5.7.5.2 Door closers

The sweep period of door closers shall be adjusted so that the door takes 3 s or more to move from an open position of 90° to a semi-closed position of approximately 12°.

5.7.6 Door-opening force

See CSA/ASC B651 for door-opening force requirements.

Note: Where the opening or closing force of a door cannot be adjusted to meet door-opening force requirements, consider a power-assisted door opener.

5.7.7 Power-assisted doors

5.7.7.1 General

Roughed-in electrical shall be provided for the future installation of a power-assisted door at the bathroom addressed in Clause [5.9](#), main entrance, and garage entrance

where an accessible parking space is provided (see Clause [4.3.3](#)).

Note: Roughing in electrical boxes at other doors, such as doors to the backyard, can also be beneficial.

5.7.7.2 Power-assisted door operation

Where provided and installed, a power-assisted door shall

- a) take 3 s or more to move from a closed to fully open position, except when a safety sensor is installed;
- b) remain fully open for a minimum of 5 s; and
- c) require a force of not more than 65 N to stop door movement, except when the door is equipped with a safety sensor that automatically stops the door if there is an obstruction in the path of movement.

5.7.7.3 Location of controls

Controls used to open power-assisted doors shall be

- a) located along the accessible path of travel;
- b) clearly visible before reaching the door;
- c) adjacent to a clear floor area of 820 by 1390 mm; and
- d) not less than 600 mm and not more than 1500 mm from the latch edge of the door, where the door swings outward.

5.7.7.4 Controls

Controls used to activate power-assisted doors shall comply with Clause [4.5](#) except where the device is also intended to be activated by a foot or lower extremity; in such cases, the height may be lowered to less than 400 mm.

5.7.8 Door viewers

Where the main entrance door is not served by a vision panel either in the door or off to the side, the main entrance door shall be equipped with dual door viewers installed at

- a) 1500 to 1700 mm above the finished floor; and
- b) 1000 to 1200 mm above the finished floor.

5.7.9 Vision panels and side lights

Where provided, a vision panel in a door or side light at minimum shall have

- a) its lower edge not higher than 900 mm above the finished floor; and
- b) an upper edge not lower than 1700 mm above the finished floor.

Note: It is beneficial for entrance doors to have a vision panel or side light that is accessible for viewing.

5.7.10 Communication systems

Where provided, doorbells, intercoms, and door cameras shall comply with Clause [4.5](#).

For short-term residential accommodations, doorbells, intercoms, and door cameras shall

- a) where connected to a security release door opener, have a visual and audible signal at the entrance to indicate a “go ahead” action; and
- b) be connected to a communication system within the unit.

Notes:

- 1) A combination doorbell, intercom, and door camera can provide additional security for dwelling occupants. Consider connecting communication systems to mobile devices (e.g., phones, tablets) to permit individuals to use their preferred activation devices (see Clause [5.14](#)).
- 2) Hardwired devices are recommended for those who might not be able to rely on Wi-Fi or battery-powered devices.
- 3) Consider Bluetooth or Wi-Fi enabled devices connected to a home router to take advantage of advancements in technology.
- 4) Consider motion sensor lighting at exterior landing and along accessible paths of travel.
- 5) An intercom system can include a TTY.
- 6) A shelf at the door offers a place to put belongings while opening the door.

- 7) Connecting the intercom system to the unit telephone system enables the occupant to access the intercom from any telephone. In addition, people who require adaptations for volume control, manipulation of buttons or receivers, or a visual “ringing” system may already have these on their telephones.
- 8) An intercom system may include a TTY or a closed-circuit television.

5.8 Interior circulation

5.8.1 Accessible path of travel – Horizontal

A horizontal interior accessible path of travel shall have a clear width at least 1200 mm (except for home alterations where a minimum of 1000 mm is acceptable) with the following exceptions:

- a) for short indentations up to 600 mm in length, the width shall be at least 860 mm (see Figure [28](#)); and
- b) for doorways, the width shall be at least 860 mm with a manoeuvring area in accordance with Clause [5.7.2](#).

Figure 28
Width of interior accessible path of travel for new construction
(See Clause [5.8.1.](#))

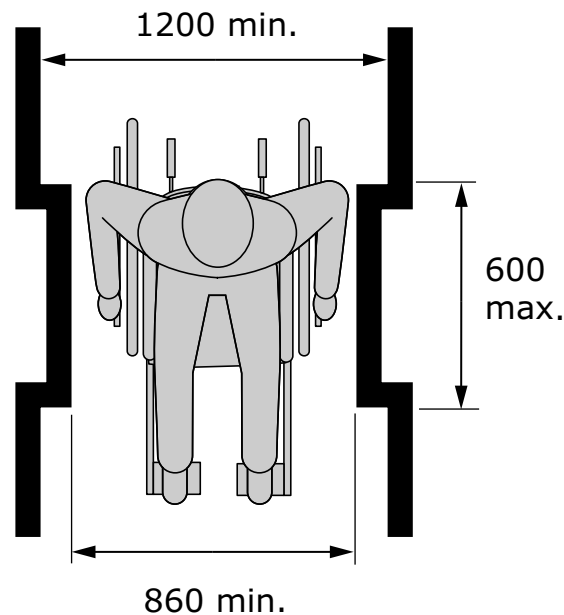

This figure shows a person in an assistive mobility device manoeuvring through a pathway with a temporarily reduced width. A standard pathway width of 1200 mm is noted with a reduced pathway width of 860 mm through the pinch point area, which has a maximum length of 600 mm.

Note: All dimensions are in mm.

5.8.2 Accessible path of travel – Vertical

5.8.2.1 General

Where an accessible dwelling has more than one storey, a means of accessible access between stories shall be provided. Raised or sunken floor levels shall not be permitted within a single storey unless connected to that storey by an accessible path of travel.

5.8.2.2 Elevating devices

Where an elevating device forms part of an accessible path of travel, it shall comply with either

- a) Appendix E of ASME A17.1/CSA-B44 for elevators and service lifts;
- b) CAN/CSA-B613 for platform lifts within a dwelling; or
- c) CAN/CSA-B355 for an elevating device whose change in level is not more than
 - i) 7000 mm for an enclosed runway; or
 - ii) 2500 mm for an unenclosed runway.

Notes:

- 1) From an accessibility standpoint, having everything in a dwelling situated on one level is ideal and avoids concerns about passenger lift malfunctions or downtime during annual maintenance checks.
- 2) Within multi-level dwellings, the number of levels that can be served by an elevating device depends on the device used as well as the dwelling layout.
- 3) Elevators and vertical or inclined platform lifts are usable by all people, including users with a walker, wheelchair, or scooter (depending on size). Stair-mounted chair lifts only accommodate people who can sit on the chair.
- 4) Most inclined platform or chair lifts can be folded against the wall when not in use to maximize the clear stair width. Such lifts are easier and cheaper to install on a straight flight of stairs than on a flight that curves or turns a corner.
- 5) Depending on the device, consideration should be given to issues relating to required stair width, fire safety, headroom clearance, clear floor area for entering/exiting the device, safety features, power/drive mechanisms, and operating controls.

5.8.3 Emergency egress

Whether it is an alteration or new construction, the design of an accessible dwelling shall take into account the need to evacuate in an emergency. At least one accessible access to the exterior shall be available from each floor level.

On the entry level, this accessible access to the exterior shall be a door. On a lower or upper level, this accessible access shall be provided by

- a) a patio, deck, or balcony served by an accessible path of travel; or
- b) an elevator or lift device with the means to remain operable during a power outage.

Notes:

- 1) At times when an elevator or lift is out of service, having alternative evacuation equipment available on the upper or lower level can be beneficial.
- 2) For additional safety, consider equipping an accessible residential unit with a sprinkler system.
- 3) Provincial/territorial and local regulations and by-laws may apply regarding emergency safety.

5.9 Bathroom(s)

5.9.1 General

At least one bathroom in an accessible dwelling shall comply with all the provisions of Clause [5.9](#). In a visitable dwelling, the bathroom is exempt from meeting the requirements for showers and bathtubs in Clauses [5.9.13](#) and [5.9.14](#).

Notes:

- 1) If the end user is available during the design, include them when making decisions regarding the type and placement of features (e.g., toilet, grab bar, shower seat), including their location and heights.
- 2) A visitable dwelling bathroom that contains only a sink and toilet is acceptable, though a full bathroom is preferable.

5.9.2 Turning space

An accessible dwelling shall have a minimum of one accessible bathroom that shall accommodate a turning circle in

accordance with Clause [4.4.2 b](#)). This turning circle may overlap with door swings, and knee and toe clearances.

Notes:

- 1) Consider making all bathrooms within the dwelling accessible.
- 2) Accommodating a larger turning circle can allow increased manoeuvring space in front of or beside all fixtures (i.e., toilets, sinks, showers, bathtubs, doors, and storage). Refer to Figures [2 b](#)) and [2 c](#)) for increased manoeuvring spaces.
- 3) The turning circle can overlap the shower [see Figures [29 a](#)) and [29 b](#))].

Figure 29 a)
Bathroom area allowances – Bathtub
 (See Clause [5.9.2.](#))

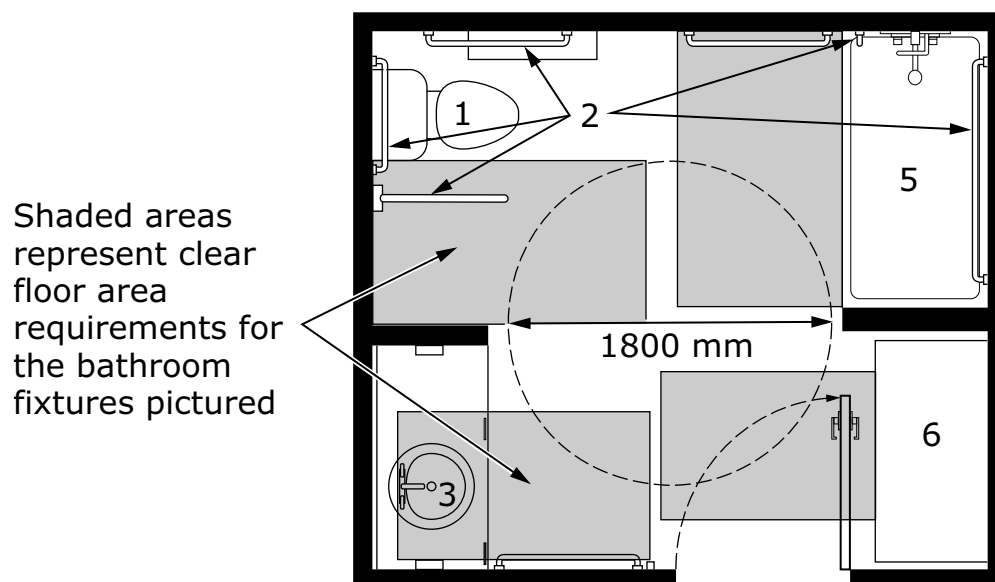

In this figure, a bathroom layout with a tub is shown. A turning circle of 1800 mm is shown in the centre of the image, overlapping the clear floor area requirements for the other bathroom fixtures. Shaded areas represent the clear floor area requirements for the pictured bathroom fixtures.

Figure 29 b)
Bathroom area allowances – Shower stall
 (See Clause [5.9.2.](#))

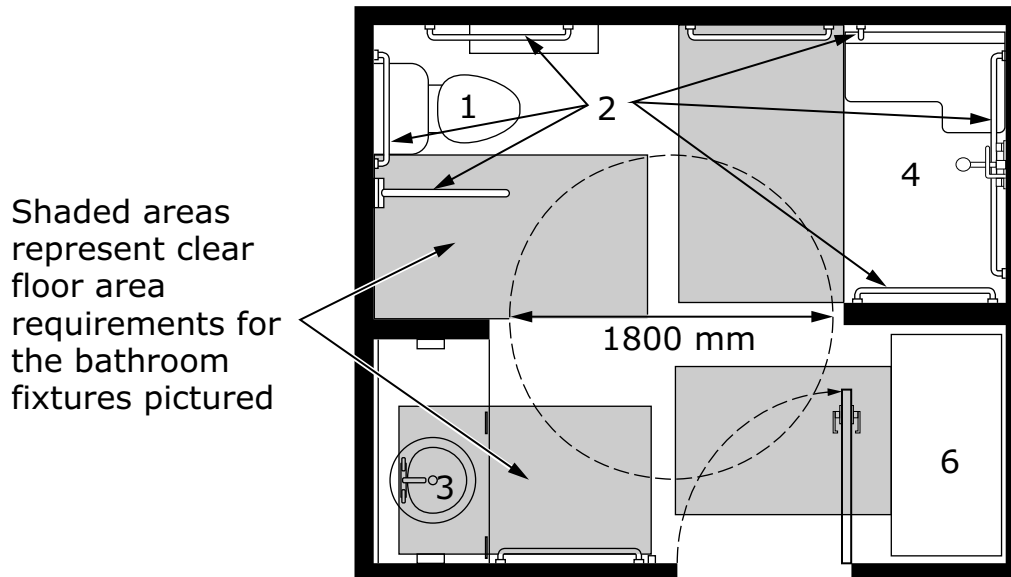

This figure shows a shower stall in place of a tub. A turning circle of 1800 mm is shown in the centre of the image, overlapping the clear floor area requirements for the other bathroom fixtures. Shaded areas represent the clear floor area requirements for the pictured bathroom fixtures.

Legend for Figures [29 a\)](#) and [29 b\)](#):

- 1) Toilet (see Clause [5.9.10](#))
- 2) Grab bars (see Clause [5.9.11](#))
- 3) Sink (see Clause [5.9.12](#))
- 4) Shower (see Clause [5.9.13](#))
- 5) Bathtub (see Clause [5.9.14](#))
- 6) Bathroom storage (see Clauses [5.9.15](#) and [5.9.16](#))

5.9.3 Doors

Bathroom doors shall comply with Clause [5.7](#).

Note: Doors are generally easier to push closed than to pull; therefore, it is preferable to provide inward-swinging or sliding (i.e., barn or pocket) doors for bathrooms, while ensuring that push and pull clearances comply with Clause [5.7.2](#). Door pulls may be installed if necessary.

5.9.4 Floors

Bathroom floors shall

- a) comply with Clause [4.6](#);
- b) if using a pre-manufactured shower base, provide fully supporting substructure; and
- c) provide luminance (colour) contrast from the walls.

Note: Some people might use the floor for part of their hygiene routine; therefore, in-floor heating should be considered for additional comfort. Some people with disabilities and some older adults have poor thermoregulation, and heated floors can provide an additional heat source.

5.9.5 Wall reinforcing

Bathroom walls shall

- a) outside of the bathtub or shower, have solid wood or plywood backing on all walls between 400 and 1600 mm above the finished floor [see Figures [30 a\)](#) and [30 b\)](#)];
- b) have solid wood or plywood backing
 - i) around the walls surrounding a bathtub, from the bathtub rim to the underside of the ceiling or a maximum of 2050 mm above the finished floor (see Figure [31](#)); and
 - ii) around the walls surrounding a shower, from the shower base to the underside of the ceiling or a maximum of 2050 mm above the finished floor (see Figure [32](#)); and
- c) be capable of supporting grab bars and accessories in

accordance with manufacturers' specifications and resist a force of at least 1.3 kN applied in any direction.

Notes:

- 1) Reinforcing could be eliminated where walls are constructed of a material (e.g., concrete, masonry) capable of supporting 1.3 kN force.
- 2) It is recommended that water-resistant or waterproofed materials be used for the bathtub or shower walls.
- 3) Wall finishes should be durable and impact-resistant.
- 4) A structural support area in the walls allows grab bars to be installed to respond to the individual needs of the occupants. Providing structural support allows for maximum flexibility in locating grab bars and other equipment.

Figure 30 a)
Bathroom wall backing (reinforcement)
(See Clause [5.9.5.](#))

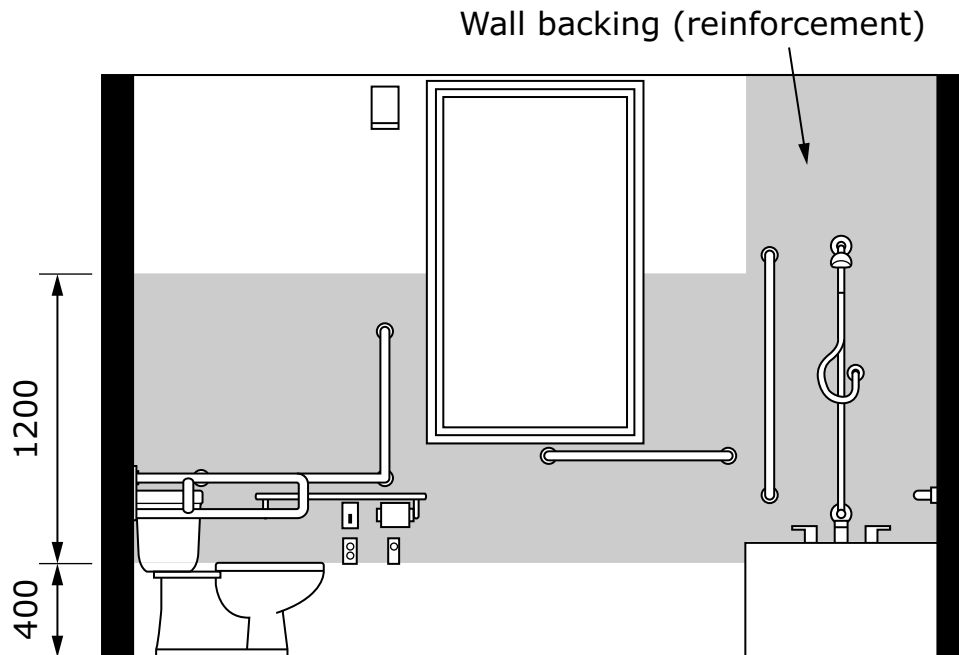

This figure shows the profile view of a sample bathroom layout that uses grey shading to show how the bathroom wall backing (i.e., reinforcement) is placed 400 mm above the ground to a height of 1200 mm, except at the tub where the wall backing extends to the ceiling.

Note: All dimensions are in mm.

Figure 30 b)
Bathroom wall backing (reinforcement) —
Three-dimensional view
(See Clause [5.9.5.](#))

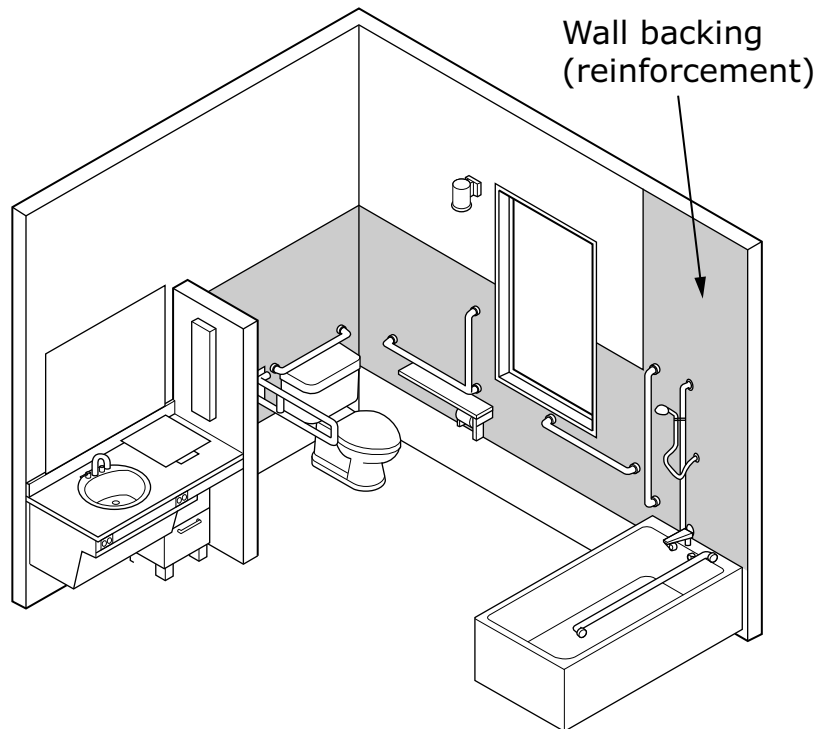

This figure shows a three-dimensional sample bathroom layout, with the shaded area indicating where wall backing is applied.

Figure 31
Bathroom wall backing surrounding bathtubs
(See Clause [5.9.5.](#))

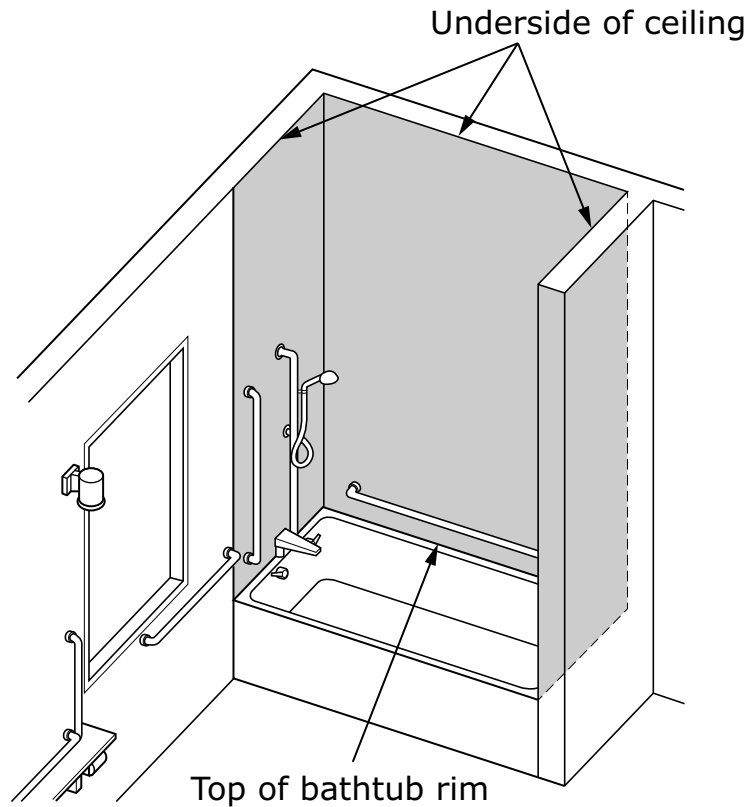

This figure shows bathroom wall backings surrounding a bathtub. The backing is shown to be mounted below the underside of the ceiling and ends at the top of the bathtub rim.

Figure 32
Bathroom wall backing surrounding showers
(See Clause [5.9.5.](#))

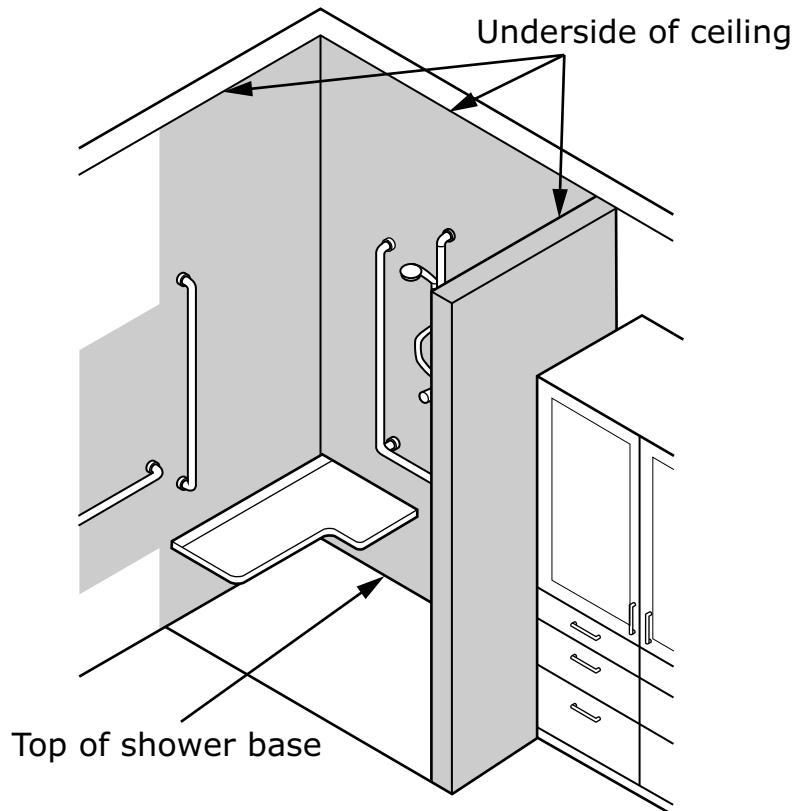

This figure shows bathroom wall backings surrounding a shower. The backing is shown to be mounted below the underside of the ceiling and ends at the top of the shower base.

5.9.6 Illumination

5.9.6.1 General

Bathroom illumination shall comply with Clause [4.8.](#)

Notes:

- 1) It is ideal to design a bathroom with as much natural light as possible.
- 2) A night light or illuminated light switch could be provided in or near the bathroom.

5.9.6.2 Vanity (task) illumination

Where provided, vanity (task) lighting shall comply with Clause [4.5](#) and should

- a) be mounted between 300 and 500 mm perpendicular to the mirror at the side, and at a minimum 1000 and 1700 mm above the finished floor (i.e., roughly eye level in seated and standing position); and
- b) be dimmable between 50 and 300 lx.

Note: Design lighting such that it avoids overhead illumination that can cast shadows under the brow, nose, and chin.

5.9.6.3 Shower and bathtub illumination

Shower and bathtub illumination shall

- a) comply with Clause [4.8](#);
- b) be moisture-proof;
- c) be dimmable between 25 and 200 lx at the base; and
- d) have a minimum of one fixture centred in the shower or bathtub ceiling (preferably recessed).

5.9.6.4 Fixture illumination

The lighting required by Clause [4.8](#) should illuminate all washroom fixtures.

5.9.7 Windows

Windows provided in the bathroom shall offer privacy.

5.9.8 Electrical

The bathroom shall have a GFCI receptacle located

- a) on a side wall adjacent to the sink not more than 150 mm from the front edge (not on the wall behind), or on the front fascia where there is a vanity; and
- b) beside the toilet
 - i) not more than 150 mm from the front edge of the toilet [see Figure [33 b](#)]; and

- ii) between 300 and 600 mm above finished floor.

Notes:

- 1) Providing an electrical outlet beside the toilet allows for future device applications such as seat lifts, bidets, etc.
- 2) Consider providing rough-in electrical boxes and cap plates for a future call system in the bathroom near the toilet.
- 3) See Figure [33 b](#)).

5.9.9 Luminance (colour) contrast

Bathroom fixtures and accessories shall luminance (colour) contrast with their surroundings.

Note: Fixtures are items such as faucets, shower heads, toilets, etc., that are fixed in a specific space. Accessories are complementary items that support the function of the space, such as a towel bar or hooks.

5.9.10 Toilet and accessories**5.9.10.1 Toilet**

The toilet shall

- a) have a lateral transfer space adjacent to the toilet on at least one side that is at least
 - i) 900 mm wide, measured from the closest edge of the toilet seat; and
 - ii) 1500 mm long, measured from the wall behind the toilet;
- b) be located between 460 mm and 480 mm from the adjacent side wall when measured from the centre line of the toilet;
- c) have a seat height between 430 mm and 485 mm above the finished floor;
- d) have a seat lid or toilet tank provided for balance and backrest;
- e) not include spring-loaded features; and
- f) have a flush activator that
 - i) complies with Clause [4.5](#) (i.e., be operable with a closed fist); and

ii) is within 350 mm from the transfer side of the toilet.

Notes:

- 1) In cases where an individual has a caregiver, transfer spaces might be necessary on both sides of the toilet.
- 2) An additional transfer space can be provided from the front of the toilet for individuals who transfer from the front.
- 3) When considering toilet styles, elongated toilet bowls, U-shaped toilet seats, heated seats, and luminance (color) contrasted toilet seats can be helpful to many people.
- 4) Walls beside the toilet should be reinforced to support grab bar installation based on the resident's preference.
- 5) For occupants who might require a higher toilet seat, seat height adapters are available.
- 6) See Figures [33 a\)](#) and [33 b\)](#).

Figure 33 a)
Toilet – Clearance areas
(See Clauses [5.9.10.1](#) and [5.9.10.2](#).)

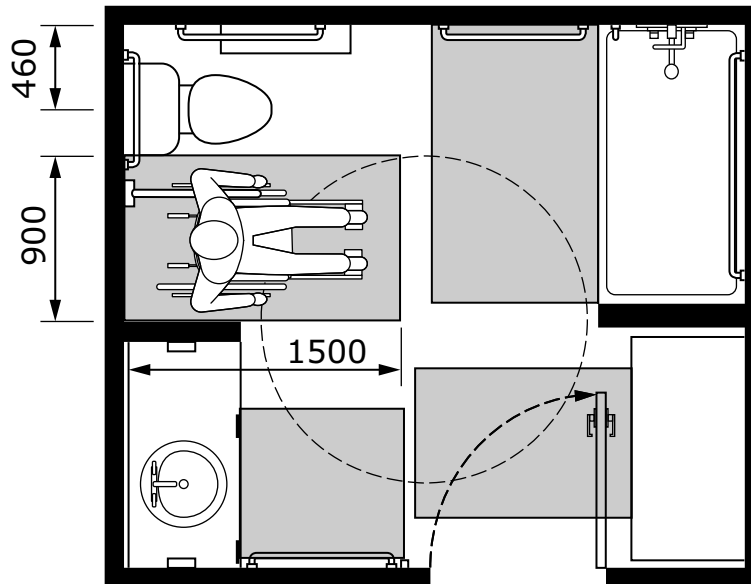

This figure shows the clearance area for various fixtures in a bathroom viewed from above. It shows the 900 mm wide transfer space next to the toilet, which is located 460 mm from the nearest side wall as measured from the toilet's centreline.

Note: All dimensions are in mm.

Figure 33 b)
Toilet — Receptacles and grab bars
(See Clauses [5.9.8](#), [5.9.10.1](#), and [5.9.10.2](#).)

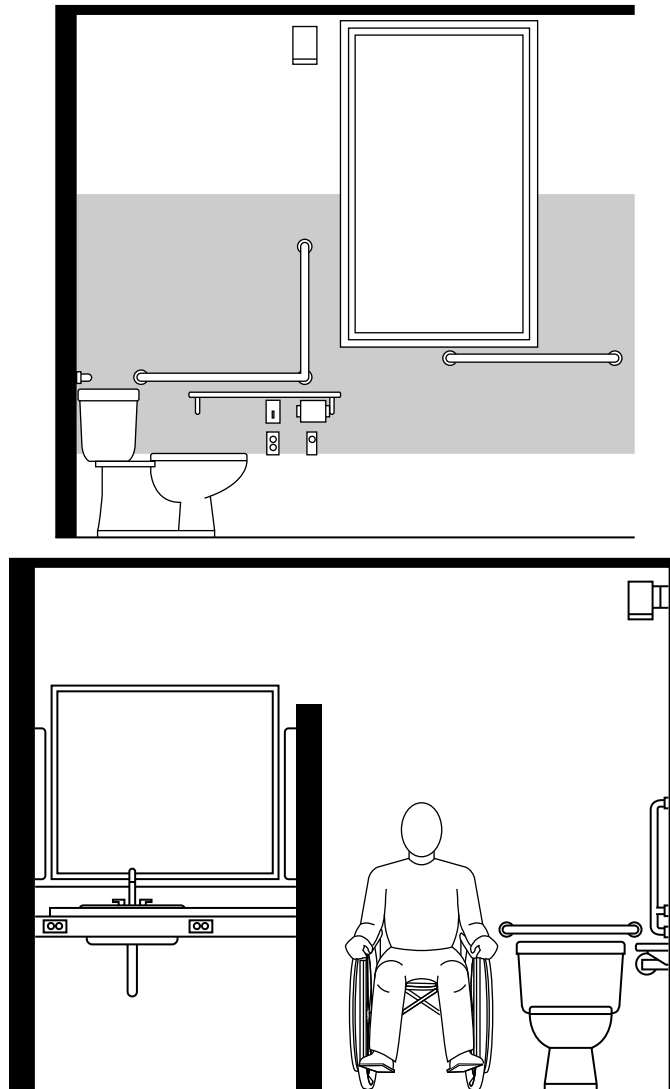

This figure shows a bathroom front and profile view depicting placement of receptacles and grab bars.

5.9.10.2 Toilet accessories

A toilet paper dispenser shall be

- a) located directly beside the toilet;
- b) within 300 mm of the front edge of the toilet; and

c) between 600 mm and 750 mm above the finished floor.

Notes:

- 1) Consider providing a shelf within reach while seated on the toilet for placing materials used for toileting.
- 2) See Figures [33 a\)](#) and [33 b\)](#).

5.9.11 Grab bars

5.9.11.1 General

Where installed, grab bars shall

- a) resist a minimum load of 1.3 kN applied vertically or horizontally;
- b) be 30 to 40 mm in diameter, or with a cross-section measuring no more than 50 mm across and 100 mm in circumference;
- c) have a space of 35 to 45 mm between the grab bar and the wall;
- d) have a minimum clearance of 305 mm with no protrusions extending beyond 40 mm above the grab bar; and
- e) be manufactured of corrosion-resistant materials.

Notes:

- 1) Small protrusions (e.g., flush actuators) can be located on the wall where the grab bar is affixed.
- 2) Grab bar location, angle, and placement are critical to a user's success. A poorly placed grab bar can create barriers, limit movement, increase stress on the joints, cause unnecessary caregiver strain, and prevent optimal use. As such, grab bars should be installed based on the occupant's needs.
- 3) Grab bars may have non-circular (i.e., oval) cross-sections and a non-slip surface to increase grip, or they may be smooth for ease of cleaning and infection control.
- 4) Some people might prefer grab bars on the left or on the right side of the toilet, which can be accomplished by reversing the layout of the toilet.

5.9.11.2 Dual-purpose grab bars

Dual-purpose grab bars should be installed in accordance with Clause [5.9.11.1](#). The accessory portion of the grab bar shall not obstruct the primary function of the grab bar.

5.9.11.3 Fold-down grab bars

Where installed, fold-down grab bars shall

- a) comply with Clause [5.9.11.1](#);
- b) maintain their upwards position when folded up (to prevent impact injuries from a falling rail); and
- c) where a top and bottom rail are present, the space between the bottom and top rail shall not exceed 120 mm to prevent entrapment.

Notes:

- 1) Fold-down grab bars may be adjacent to walls, obstructions, or other elements such as vanities and closets.
- 2) Fold-down grab bars are useful to people who require support from both sides of a toilet.
- 3) A fold-down grab bar that consists of a top and bottom rail might be easier for some people to use than rails that are offset and not directly above one another.
- 4) Minimal force should be needed to pull down the grab bar when it is in the upright position.

5.9.11.4 Horizontal pivoting grab bars

Where installed, horizontal pivoting grab bars shall

- a) comply with Clause [5.9.11.1](#);
- b) have the pivoting portion of the grab bar move freely to adjust to the location or angle of the grab bar; and
- c) be capable of securing in place when in use.

5.9.12 Sink and vanity

5.9.12.1 Sink and cabinetry

5.9.12.1.1 General

Sinks shall

- a) comply with Clause [4.4](#);
- b) be mounted with the centreline at least 460 mm from a side wall;
- c) not consider the dip of the overflow in determining knee and toe clearance;
- d) have faucets that comply with Clause [4.5](#); and
- e) have water supply and drainpipes under sinks that are
 - i) insulated;
 - ii) fully protected; or
 - iii) otherwise configured to protect against contact.

Note: Faucets can be installed at the side of the basin for ease of use and shorter reach ranges.

5.9.12.1.2 Sink installation in countertop

Where the sink is installed in a countertop, there shall be no 90° angles on the front edge profile.

Notes:

- 1) It is recommended that the edges of the countertop be bullnose or rounded.
- 2) Raised sink edges (i.e., vessel sinks) can be uncomfortable when leaning on the edge of the sink.
- 3) It is preferred that height-adjustable sinks (when used) have appropriate blocking for their safe installation.
- 4) See Table [1](#) for height ranges for children and people of shorter stature.

5.9.12.1.3 Cabinetry under the sink

Where cabinetry is provided under the sink, the cabinets shall

- a) comply with Clause [4.4.3](#);

- b) be removable without removal or replacement of the sink;
- c) have finished floor extend under the cabinetry; and
- d) have the walls behind and surrounding the cabinetry be finished.

Note: Where cabinetry is provided under the sink, doors that open and slide out of the way can be added.

5.9.12.2 Accessories

Accessories (towel bars, hooks, shelving, etc.) should comply with Clause [4.5.4](#).

Note: The installation of grab bars is preferred instead of towel bars, as towel bars can be misused for support.

5.9.12.3 Mirrors

Mirrors shall be installed with the bottom edge not more than 1000 mm above the finished floor.

Notes:

- 1) Providing a gap between the bottom of the mirror and the top of the counter prevents corrosion from water damage and supports proper cleaning.
- 2) Larger and full-length mirrors offer people who are shorter or who use assistive mobility devices the ability to fully view themselves.
- 3) Tilted mirrors should be a decision made by the resident. A fixed vertically mounted mirror is a more universal approach.

5.9.13 Shower(s)

5.9.13.1 General

At least one shower within an accessible dwelling shall comply with this Clause.

Note: Accessible showers can be designed such that they benefit all occupants.

5.9.13.2 Size

The shower stall shall

- a) have an interior clear area of at least 900 by 1500 mm; and
- b) have a clear and unobstructed floor area in front of the shower at least 900 mm deep and the same width as the shower.

5.9.13.3 Floor drainage

The floor of the shower shall

- a) be slip-resistant; and
- b) have a slope between 1% and 2% toward the drain.

Note: Consider trench or channel drainage along the side or rear of the shower in lieu of a typical central drain.

5.9.13.4 Shower heads

At least one shower head shall be provided. The shower head shall

- a) be of the handheld type;
- b) be protected with a mixing valve that limits the water temperature to a maximum of 49 °C;
- c) be provided with a hose at least 1800 mm long;
- d) allow use in a fixed position;
- e) be adjustable between 860 and 2030 mm from the floor; and
- f) not obstruct the use of the grab bars.

Notes:

- 1) Installation of two shower heads (one adjustable and one fixed) is preferred.
- 2) Adjustments of the shower head should be easy and made possible with the use of one hand.

5.9.13.5 Threshold

The shower shall have a threshold that complies with Clause [5.7.4](#).

Note: A zero-threshold shower is preferred.

5.9.13.6 Grab bars

Grab bars for a shower shall

- a) comply with Clause [5.9.11](#);
- b) include a vertical grab bar at the entrance to the shower;
and
- c) include either a horizontal and vertical grab bar or an L-shaped grab bar adjacent to (i.e., not behind) the shower seat or bench.

Note: Placement of grab bars can include a vertical, horizontal, or angled gripping surface.

5.9.13.7 Faucets and controls

Faucets and controls for the shower shall be

- a) protected with a mixing valve that limits the water temperature to a maximum of 49 °C;
- b) mounted on the back wall above the grab bar (see [Figure 34](#)); and
- c) located at a distance
 - i) between 300 mm from the inside corner of the wall and the center of the back wall; or
 - ii) not more than 300 mm from the front edge of the seat;
and
 - iii) be not more than 1100 mm from the floor.

Note: The faucet should include hot and cold temperature labels.

Figure 34
Shower
(See Clause [5.9.13.7.](#))

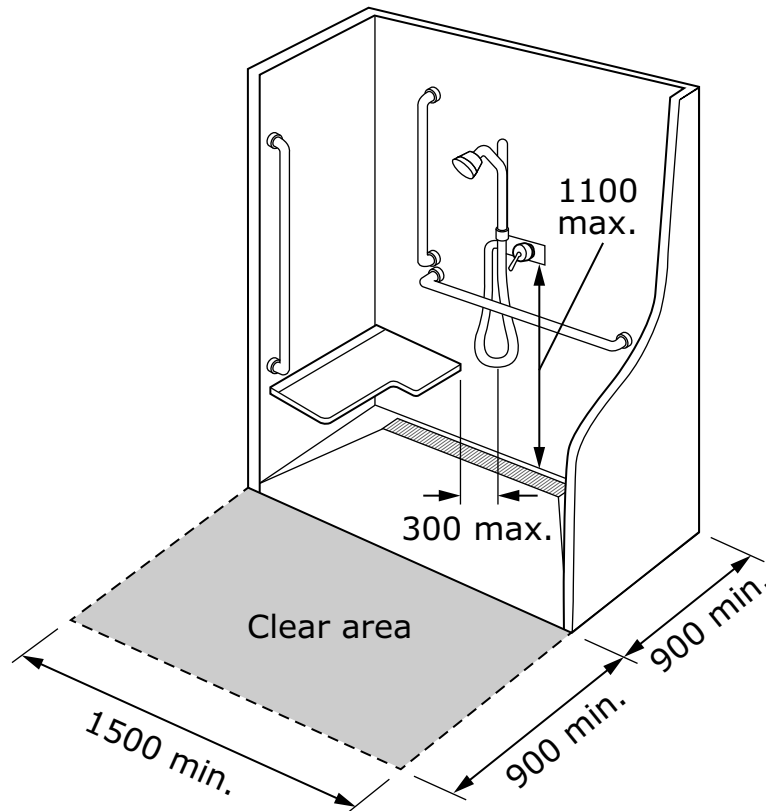

This figure shows a shower stall layout with a 1500 mm by 900 mm shower stall, and a clear area of at least 1500 mm by 900 mm in front of the shower stall. The shower faucet is mounted on the back wall above a horizontal grab bar and located a maximum of 300 mm from the front edge of the shower seat.

Note: All dimensions are in mm.

5.9.13.8 Seating

The shower should be equipped with a seat that is

- a) not spring-loaded;
- b) located on the side wall with the vertical grab bar that complies with Clause [5.9.13.6 a\)](#);

- c) at least 400 mm wide or greater to extend the full depth of the shower (less a space allowed for the shower curtain);
- d) installed with its top between 435 and 485 mm from the floor;
- e) designed to carry a minimum load of 1.3 kN; and
- f) smooth with a non-slip surface having no rough edges.

Note: Include the user in the decision of the selection, size, and placement of the shower seat.

5.9.13.9 Accessories

Where a soap niche or shelf is provided within the shower, the niche or shelf shall be within a 300 mm reaching distance of the shower seat.

Note: If providing a hook, consider locating it outside of the shower and reachable from the seated position. If a hook is provided, ensure it is mounted on a side wall not more than 1100 mm above the floor and projecting not more than 50 mm from the wall.

5.9.14 Bathtubs

5.9.14.1 General

Where provided, at least one bathtub shall have

- a) a length of at least 1500 mm;
- b) a clear and unobstructed floor area upon approach into the bathtub at least 900 mm deep and extending for the entire length of the bathtub;
- c) a slip-resistant surface;
- d) no tracks or obstructions along the entire length of the rim;
- e) its rim not more than 485 mm above the floor (unless it is a walk-in bathtub); and
- f) backing that complies with Clause [5.9.4](#) b) i).

Note: A walk-in bathtub is an option, if preferred.

5.9.14.2 Grab bars

Unless a bathtub is freestanding, a bathtub shall have

- a) grab bars that comply with Clause [5.9.11](#);
- b) a vertical grab bar at the entrance to the bathtub; and
- c) either a horizontal and vertical grab bar or an L-shaped grab bar along the back wall.

Note: Placement of grab bars can include a vertical, horizontal, or angled gripping surface.

5.9.14.3 Faucets and controls

Faucets and controls for the bathtub shall be

- a) protected with a mixing valve that limits the water temperature to a maximum of 49 °C;
- b) centred at the foot end of the bathtub; and
- c) not more than 450 mm above the bathtub rim.

5.9.14.4 Accessories

See Clause [5.9.13.9](#).

5.9.15 Medicine cabinets

A medicine cabinet shall

- a) be adjacent to a clear floor area of at least 820 by 1390 mm (which may include the knee clearance at the sink);
- b) be located within a horizontal reach of not more than 500 mm;
- c) have the bottom shelf located not more than 1000 mm from the floor;
- d) have doors and hardware that comply with Clause [5.7.5](#); and
- e) be illuminated to a level of at least 200 lx.

Note: Where possible, medicine cabinets should be recessed into walls to avoid having them project into the bathroom space.

5.9.16 Other storage

Where provided, other bathroom storage shall be installed in accordance with Clause [4.4](#) and comply with Clause [4.5](#).

Notes:

- 1) Consider both open and closed storage options.
- 2) Take advantage of wall cavities on interior walls to create storage niches, especially beside the toilet for toileting supplies.
- 3) Consider using drawers rather than doors in below-counter spaces.

5.10 Kitchens

5.10.1 Floor area at appliances and countertops

The kitchen shall

- a) comply with Clauses [4.4.1](#) and [4.4.3](#);
- b) accommodate a turning circle or T-turn in accordance with Clause [4.4.2](#);
- c) have a clear floor area at least 820 by 1390 mm
 - i) directly in front of kitchen fixtures and appliances; and
 - ii) to the one side where drawers or doors open [see Figures [35 a\)](#) to [35 f\)](#)].

For short-term residential accommodations, there should be a clear floor area of 2100 by 2100 mm between fixtures (e.g., cabinets, appliances) to provide the necessary space for mobility aid users to access the fixtures easily. If fixtures are adjacent to each other, the 2100 by 2100 mm clear floor area between fixtures can overlap.

Note: For all appliances, consider the direction of door swing and the space required to travel around an open door.

Figure 35 a)
Kitchens – Sample kitchen layout
(See Clause [5.10.1.](#))

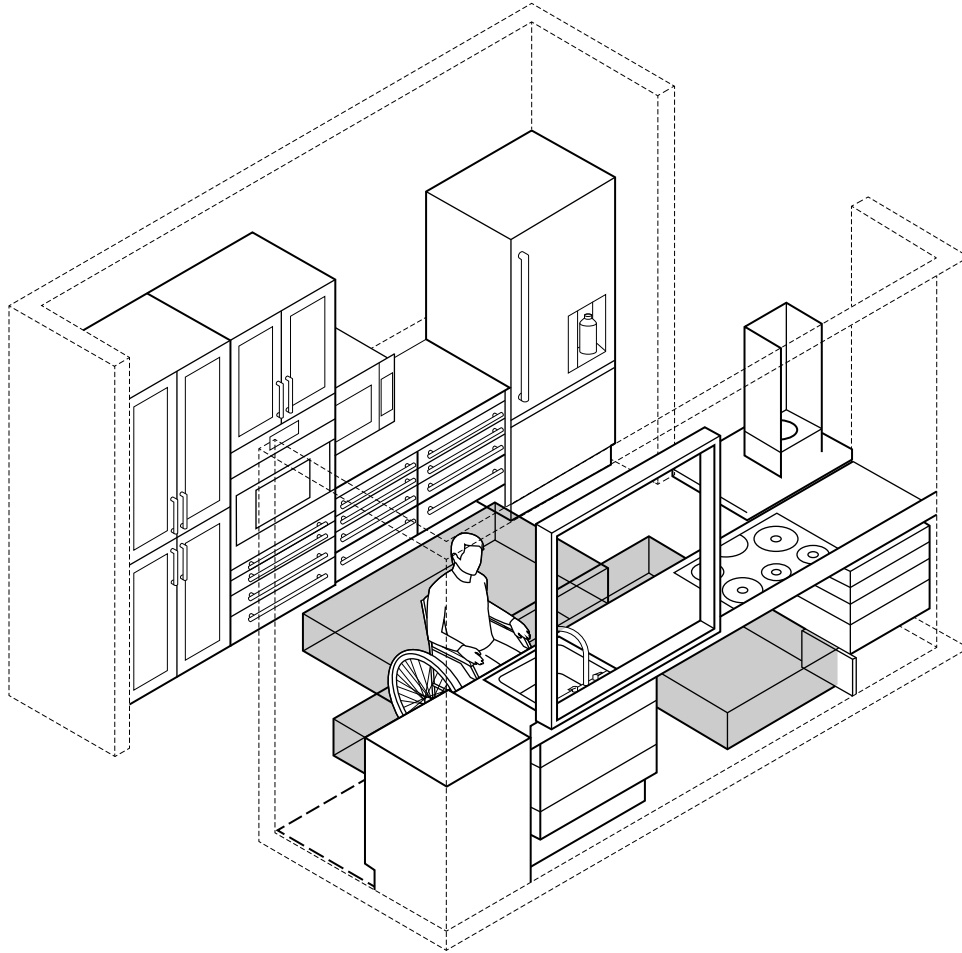

This figure is a three-dimensional image of a sample kitchen layout.

Figure 35 b)
Kitchens – Minimum clear floor spaces for galley kitchens
 (See Clause [5.10.1.](#))

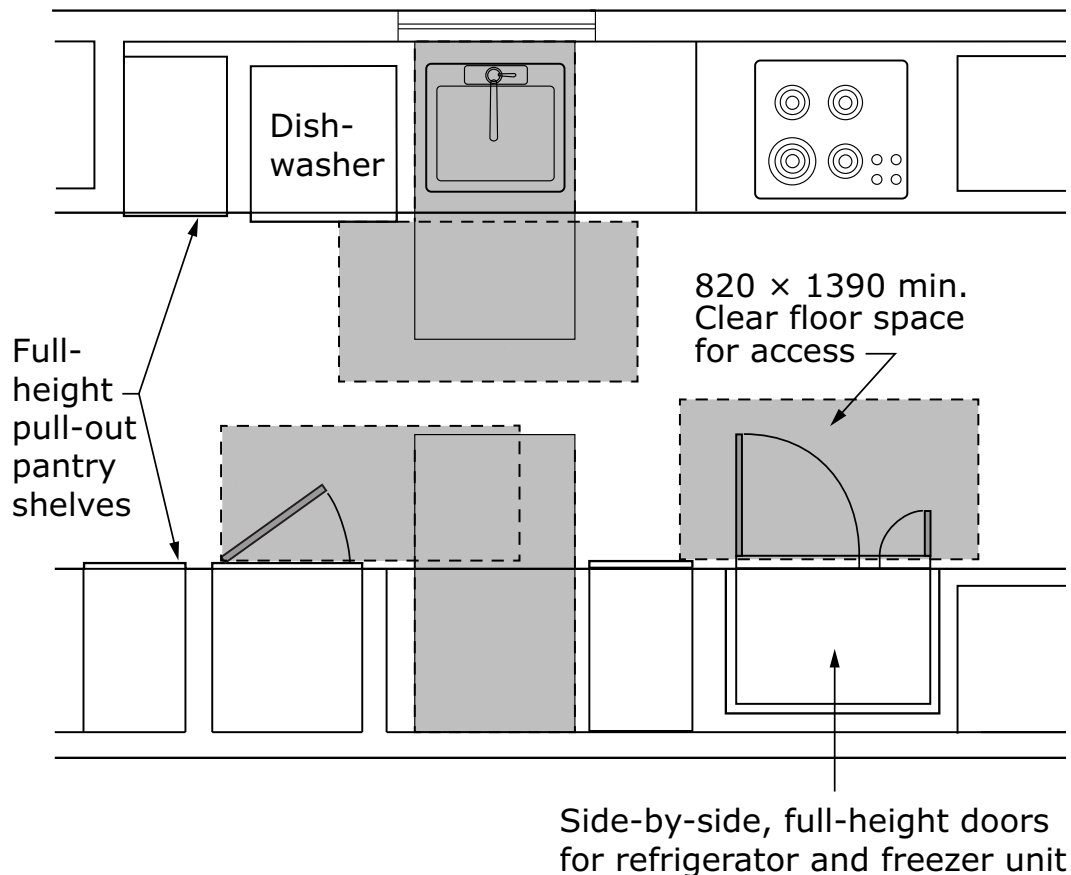

This figure displays the floor plan of a galley kitchen with full-height pull-out pantry shelves and various kitchen appliances. One side of the galley kitchen has the dishwasher, sink, and cooktop. A side-by-side full-height refrigerator and freezer unit that requires a minimum 820 mm by 1390 mm clear floor space for access is on the other side of the galley kitchen. The diagram shows that the minimum clear floor spaces to access various shelves and appliances may overlap.

Note: All dimensions are in mm.

Figure 35 c)
Kitchens – Clearances, outlet and switch placement
 (See Clause [5.10.1.](#))

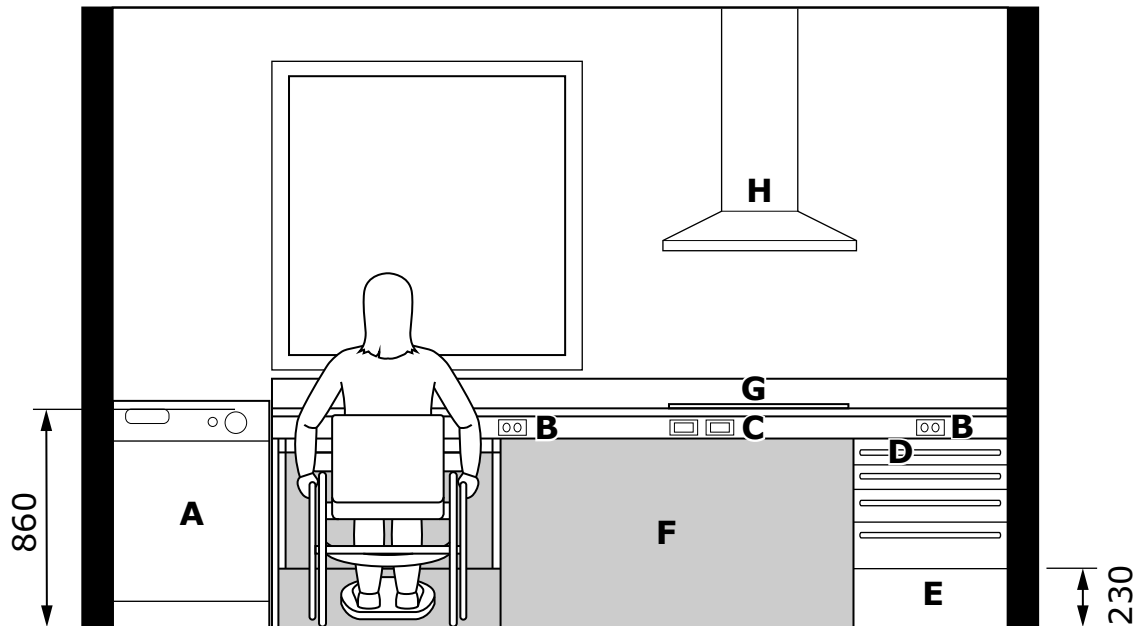

- A = Dishwasher
- B = Fascia-mounted electrical outlet
- C = Fascia-mounted switch for ventilation fan and light
- D = Pull-out shelf
- E = 230 mm high × 230 mm deep toe clearance
- F = Knee clearance
- G = Counter-mounted cook top
- H = Ventilation fan and light

This figure shows a kitchen layout with the dishwasher and cooktop displayed. The counter height is 860 mm from the floor and knee clearance is left under the counter. Electrical outlets and switches for the ventilation fan and light are mounted on the fascia.

Note: All dimensions are in mm.

Figure 35 d)
Kitchens – Toe clearance
 (See Clause [5.10.1.](#))

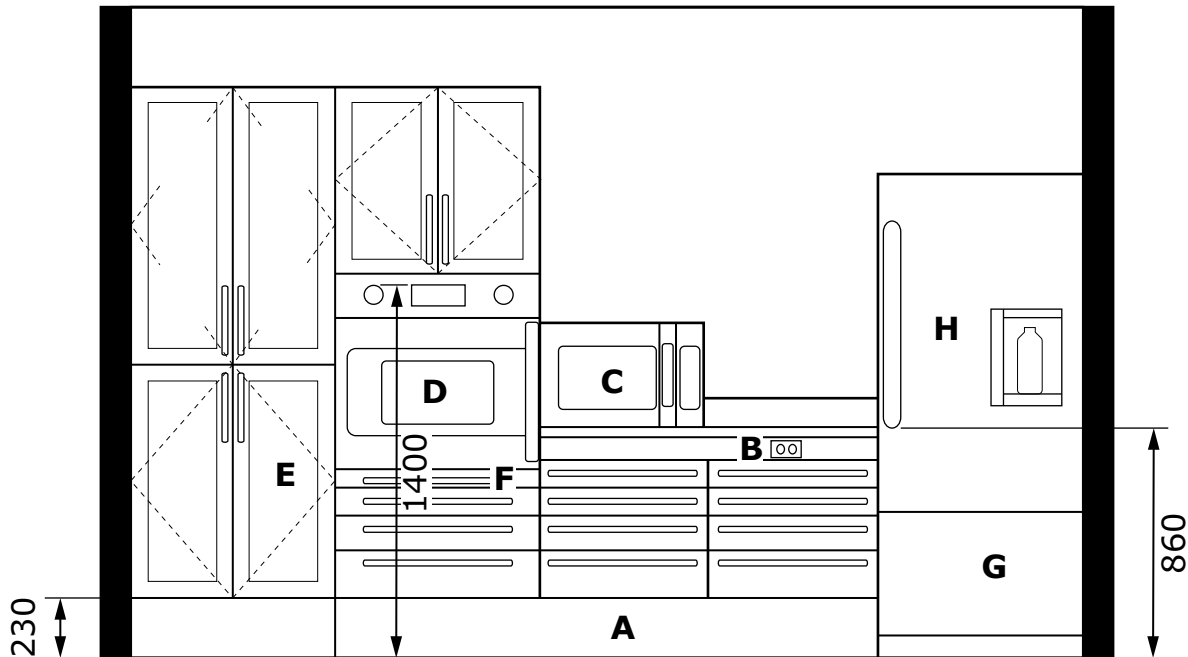

- | | |
|--------------------------------------|------------------------------------|
| A = Toe kick | E = Pantry with pull-out shelves |
| B = Fascia-mounted electrical outlet | F = Pull-out shelf below wall oven |
| C = Microwave oven | G = Drawer freezer |
| D = Wall oven (with swing door) | H = Refrigerator |

This figure shows a kitchen layout with cabinetry, microwave oven, wall oven, fridge, and pantry displayed. There is a 230 mm height clearance under the cabinetry.

Note: All dimensions are in mm.

Figure 35 e)
Kitchens – Overhead view, galley kitchen
 (See Clause [5.10.1.](#))

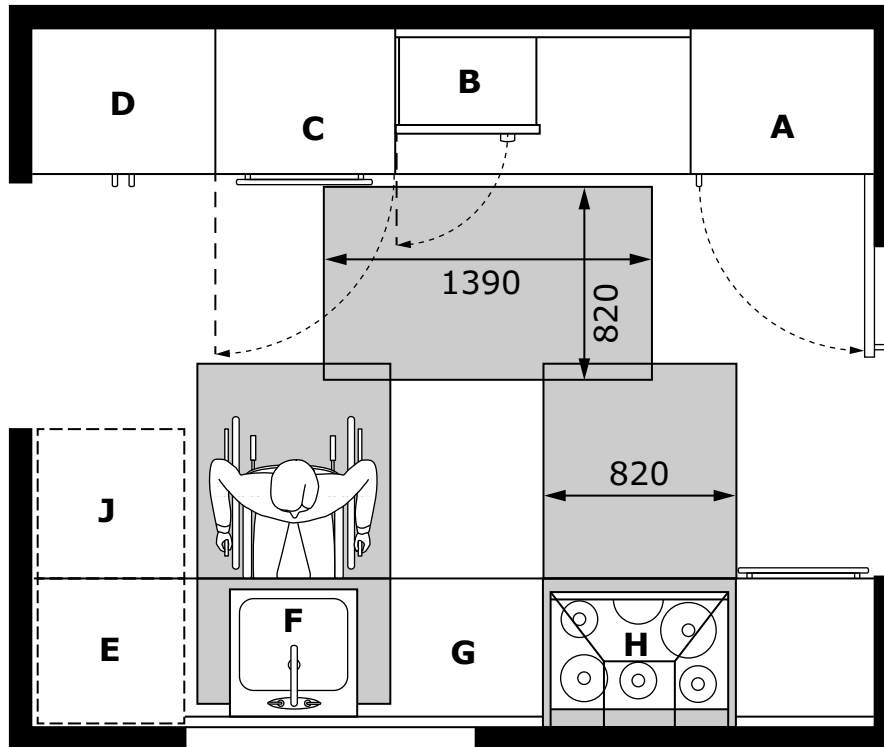

- | | |
|----------------------------------|---|
| A = Refrigerator/freezer | F = Sink |
| B = Microwave oven | G = Worksurface (min. 820 mm wide) |
| C = Wall oven (with swing door) | H = Counter-mounted cooktop |
| D = Pantry with pull-out shelves | J = Floor clearance for dishwasher door |
| E = Dishwasher | |

This figure shows an overhead view of a galley kitchen. Work surfaces with a width of 820 mm are displayed and a clear floor area 1390 by 820 mm is displayed in front of the work surface. A clear floor area space 820 mm wide is shown in front of the stove.

Note: All dimensions are in mm.

Figure 35 f)
Kitchens — Overhead view, L-shaped kitchen
 (See Clause [5.10.1.](#))

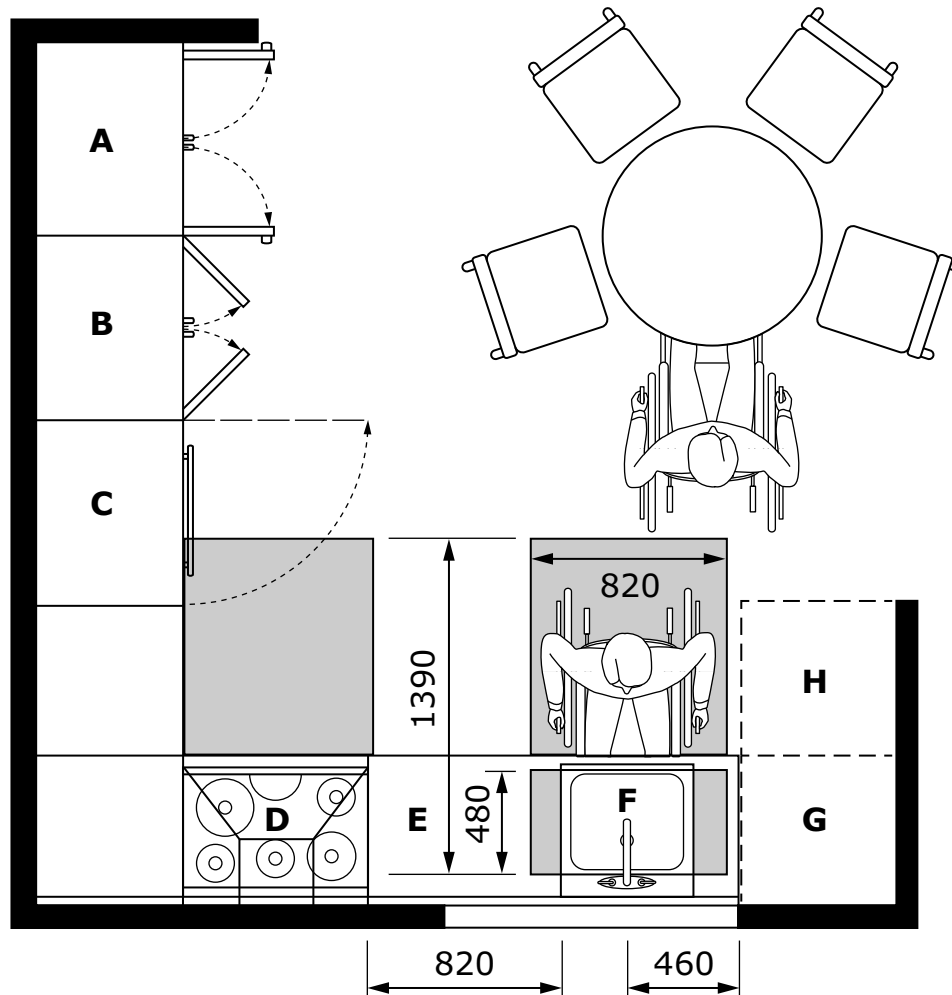

- | | |
|---------------------------------------|---|
| A = Refrigerator/freezer | F = Sink |
| B = Pantry with pull-out shelves | G = Dishwasher |
| C = Wall oven (with swing door) | H = Floor clearance for dishwasher door |
| D = Counter-mounted cooktop | |
| E = Worksurface
(min. 820 mm wide) | |

Figure 35 f) (Concluded)

This figure shows the overhead view of an L-shaped kitchen layout with a kitchen table that accommodates five people. Work surfaces with a width of 820 mm are displayed and a clear floor area 1390 by 820 mm is displayed in front of the sink.

Note: All dimensions are in mm.

5.10.2 Doors

The kitchen should not be served by doors or have any barriers to entry. If a kitchen door or doorway is provided, it shall comply with Clause [5.7](#).

5.10.3 Floors and walls

The kitchen floor shall

- a) comply with Clause [4.6](#); and
- b) be luminance (colour) contrasted from the walls, millwork, and appliances.

Note: Consider providing reinforcing within kitchen walls and ceilings to help those who require a lift or other device to complete daily activities (e.g., transferring hot or heavy cooking, or transferring to a dining chair).

5.10.4 Illumination

All kitchen illumination, including appliances and any task lighting below overhead cabinetry, shall comply with Clause [4.8](#).

Note: Task lighting within a kitchen aids in safety and helps with increased visibility while using appliances or preparing meals.

5.10.5 Electrical

The kitchen electrical shall

- a) comply with Clause [4.5](#);
- b) include switches and outlets on front faces of counters;
- c) include side wall outlets, where applicable; and

d) if a range hood is installed, be operable from the seated position or have a remote control.

Note: Outlets can be installed along the backs of counters; however, to improve reaching ranges for several individuals, having options at the front faces of counters and alongside side walls is critical for improved use and access.

5.10.6 Counters

At least one section of counter shall

- a) have a counter surface height and knee and toe clearances under the counter comply with Clause [4.4.3](#);
- b) be at least 820 mm wide by 600 mm deep;
- c) have no sharp or abrasive surfaces under it;
- d) have heat-resistant surface material;
- e) have no 90° edges; and
- f) resist a minimum load of 1.3 kN applied vertically at the front edge of the counter.

Notes:

- 1) It is recommended that the edges of the countertop be bullnose or rounded.
- 2) It is recommended that the accessible portion of the countertop contain or have access to an electrical outlet.
- 3) Multiple-height counters can be helpful to accommodate all users.
- 4) Consider a pull-out workboard below the standard countertop level.
- 5) Countertops linking the kitchen appliances should be continuous.
- 6) A luminance (colour) contrasted front edge on the counters can help define the user space.
- 7) For a front-approach to work with a clear floor area of 820 by 1390 mm, the knee clearance should be centred (e.g., cooktop, sink).

5.10.7 Sink

A sink shall have

- a) a counter or rim height (whichever is higher) and a knee clearance below the sink that comply with Clause [4.4.3](#), unless the sink is adjustable in which case the counter or rim height shall be between 730 mm and 1040 mm;
- b) a centreline at least 460 mm from a side wall;
- c) faucets that comply with Clause [4.5](#); and
- d) water supply pipes and drainpipes underneath that are
 - i) insulated;
 - ii) fully protected; or
 - iii) otherwise configured to protect against contact.

Notes:

- 1) Sink depths not deeper than 180 mm may be used to achieve this knee clearance.
- 2) Consider adding an automatic, touch-activated or motion-activated faucet (i.e., touch or touchless faucets). Having an automatically activated temperature indicator added to the kitchen faucet can also be helpful.
- 3) Faucets can be installed at the side of the basin for ease of use and shorter reach ranges.

5.10.8 Storage

Storage in the kitchen shall include options that

- a) comply with Clause [4.4](#);
- b) have both open and closed storage options; and
- c) where closed storage is included
 - i) comply with Clause [4.5](#);
 - ii) be drawer-style when located under counter surfaces;
 - iii) have 300 mm deep overhead shelves that are a maximum of 1100 mm above the finished floor, or be able to be drop down either manually or through automation; and

- iv) have base cabinets (where used) with a toe space at least 150 mm deep by 230 mm high.

Notes:

- 1) Examples of convenient accessible storage include open storage or pull-out pantry style shelving, mechanisms such as soft-close drawers, Lazy Susans in corner cabinets, and doors and shelves that can be lowered with a pull or electronically.
- 2) Full-extension drawers, pull-outs, or drop-down shelves are often easier for people to use than shelving that requires someone to reach or bend to access stored items.
- 3) Full-height storage cabinets provide a good range of accessible storage, which is particularly useful in kitchens where base storage is reduced due to knee clearance provisions.

5.10.9 Appliances

5.10.9.1 Operable controls

All appliances shall have operable components that comply with Clause [4.5](#).

Notes:

- 1) Safety features such as automatic shut-off or cool-to-touch should be considered.
- 2) It is recommended that automatic appliances be easy to use from a mobile device, or be voice-activated.

5.10.9.2 Refrigerator and freezer

If provided, the kitchen refrigerator shall be counter-depth.

If an over-and-under type refrigerator is provided, the freezer shelf height shall not be more than 1100 mm from the floor.

Notes:

- 1) A counter-depth fridge allows an individual (e.g., someone using an assistive mobility device) to access the back of the fridge.
- 2) It is recommended that the freezer be self-defrosting (i.e., frost-free).

- 3) Where a standalone freezer is being installed, select an upright model rather than chest style.
- 4) Design the kitchen layout and appliance placement to permit easy access to refrigerator drawers and pull-out shelves.
- 5) To provide more flexibility to the kitchen designer and homeowner, refrigerators with the preferred door swing direction can be purchased. Otherwise, choose a door swing direction that opens the contents of the fridge towards the other appliances, not away.
- 6) Side-by-side refrigerators are generally more accessible, but they are wider and can be taller.
- 7) For the over-and-under models, the freezer should be at the bottom.
- 8) Roll-out shelves or drawers improve access to the refrigerator contents.
- 9) Through-the-door ice and water dispensers are convenient for many users.

5.10.9.3 Cooktop

Where provided, a cooktop shall

- a) have controls that
 - i) are located in front of or beside the hot surface; and
 - ii) operate with automatic ignition on gas burners;
- b) be installed
 - i) flush or level with the countertops that comply with [Clause 5.10.6](#);
 - ii) with a cooking surface height and knee and toe clearance complying with [Clause 4.4.3](#);
 - iii) such that the underside of the knee clearance is
 - 1) insulated;
 - 2) fully protected; or
 - 3) otherwise configured to protect against contact; and
 - iv) with a 400 mm wide clear countertop space adjacent to it at the same level; and

- c) where provided, have a range hood that
 - i) is not less than 710 mm above the cooktop surface; and
 - ii) complies with Clause [4.5](#).

Notes:

- 1) Consider having a pot filler above the cooktop where controls comply with Clause [4.5](#), or place the sink on the same side as the cooktop.
- 2) A separate cooktop and wall oven are recommended over a traditional stove for increased safety while cooking. Each can then be placed at a height that more easily accommodates a person who is seated, allowing the person to be able to see into a pot on the cooktop and reach safely into the oven.
- 3) Induction cooktop surfaces or heating plates can improve safety within the kitchen.
- 4) It is helpful to have a storage drawer located on one side of the cooktop.
- 5) Consider a pull-out shelf adjacent to the cooktop surface for extra workspace.

5.10.9.4 Oven

Where provided, an oven shall

- a) be a built-in wall oven with controls located between 1200 and 1400 mm above the floor; and
- b) have a pull-out heat-resistant shelf
 - i) with a depth of at least 250 mm; and
 - ii) located underneath or adjacent to the wall oven.

Notes:

- 1) Side swing oven doors are preferred for accessibility, as it allows the user to remain clear of the oven door opening, eliminates the need to lift a heavy door, and reduces the risk of burns from hot surfaces.
- 2) When installed, the oven base should be approximately 710 mm above the floor.
- 3) The location of the pull-out drawer will depend on the oven door swing.

4) Consider self-cleaning ovens.

5.10.9.5 Microwave

Where provided, a microwave shall be located on a work surface a maximum of 860 mm above the finished floor and have a clear counter space of at least 400 mm adjacent to the latch side of the door opening.

5.10.9.6 Dishwasher

Where provided, a dishwasher shall

- a) be a single-door or drawer type;
- b) have knee clearance provided on at least one side of the dishwasher in accordance with Clause [4.4.3](#); and
- c) have controls located on the top or front of the door.

Note: A dishwasher with a “quiet feature” can be helpful to reduce noise within a living space.

5.11 Bedrooms

Notes:

- 1) Consider designing all bedrooms as accessible to allow for participation in daily living activities and for the opportunity of choice in bedroom selection.
- 2) Accessibility within the bedroom considers aspects such as space to manoeuvre around furniture, placement of electrical switches and outlets, luminance (colour) contrast, and safety for travel to the bathroom at night.

5.11.1 Area requirements

5.11.1.1 General

The bed within the bedroom shall be served by an accessible path of travel complying with Clause [4.4.1](#) on at least three sides.

Notes:

- 1) Where provided, accessible guest rooms should be designed with a bed height of between 430 and 460 mm from the floor so

that people can easily transfer from a mobility device to the bed. This is an exception to the seat height requirements elsewhere in this Standard.

- 2) For short-term bedroom accommodations, consideration should be given to the accessibility of furnishings whether they are fixed or movable.
- 3) Tables, whether built-in or portable, should have a knee clearance of at least 820 mm wide by 480 mm deep by 685 mm high to accommodate mobility devices.

5.11.1.2 Features

Bedroom features such as dressers, cabinets, and closets shall be served by a clear floor space complying with Clause [4.4.2 b\)](#) [see Figures [36 a\)](#) to [36 b\)](#)].

Notes:

- 1) Consideration should be made for situations where more clearance might be needed for an assistive mobility device to get around a bed on either side, where a lift might be in use, or to access an emergency exit route.
- 2) When a queen size bed is provided, a minimum 4458 mm wide by 4633 mm long bedroom should be provided to allow for an adequate manoeuvring area. The minimum width can be reduced when a smaller bed (i.e., twin or single) is provided.

Figure 36 a)
Bedroom — Three-dimensional layout
(See Clauses [5.11.1.2](#) and [5.11.5.](#))

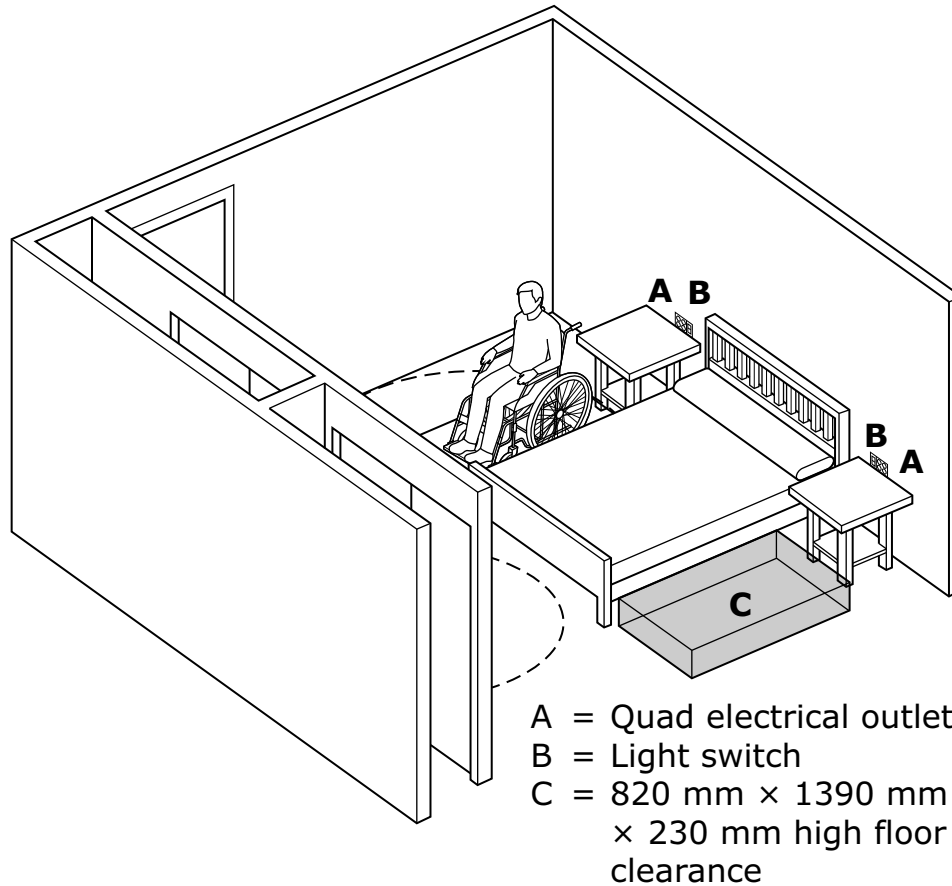

- A = Quad electrical outlet
- B = Light switch
- C = 820 mm × 1390 mm
× 230 mm high floor
clearance

This figure shows a three-dimensional bedroom layout with quad electrical outlets, light switches, and floor clearances that are 820 mm long by 1390 mm wide by 230 mm high on either side of a bed.

Note: All dimensions are in mm.

Figure 36 b)
Bedroom – Side view
 (See Clauses [5.11.1.2](#) and [5.11.5.](#))

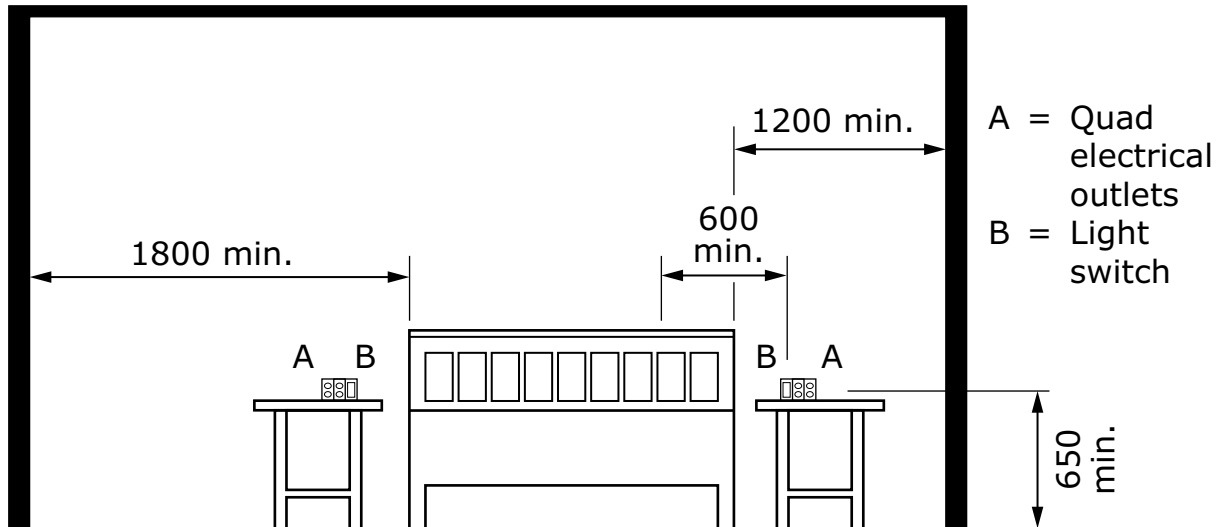

This figure shows the quad electrical outlet and light switch on either side of the bed is located 650 mm from the floor. It also shows the edge of the bed is located at least 1800 mm from one wall and at least 1200 mm from the opposite wall.

Note: All dimensions are in mm.

Figure 36 c)
Bedroom — Overhead view
 (See Clauses [5.11.1.2](#) and [5.11.5](#).)

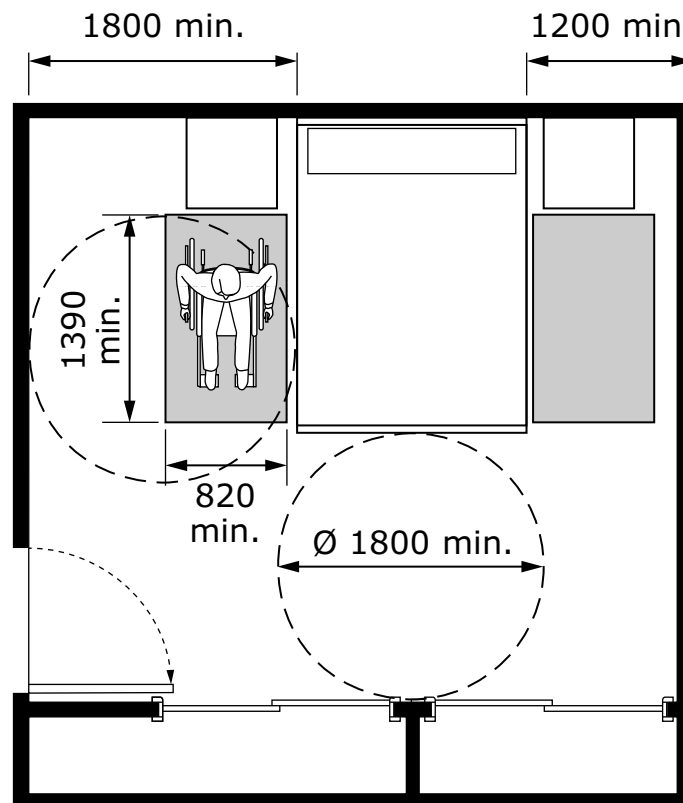

This figure shows an overhead view of the bedroom, noting there is at least 1800 mm of floor space between one wall and the bed and between the foot of the bed and the wall, and at least 1200 mm floor space between the opposite wall and the bed.

Note: All dimensions are in mm.

5.11.2 Floors

Bedroom floors shall luminance (colour) contrast with the walls.

5.11.3 Illumination

Bedroom illumination shall comply with Clause [4.8](#).

Note: Consider having lighting available on both sides of the bed.

5.11.4 Windows

A window shall be provided in the bedroom in accordance with Clause [4.9](#).

5.11.5 Electrical

Bedroom electrical shall

- a) comply with Clause [4.5](#);
- b) at a minimum, provide one switch (light, fan, etc.) beside the bed at a height between 550 mm and 650 mm above the floor [see Figures [36 a\)](#) to [36 c\)](#)];
- c) have two walls with a minimum of two quad receptacle outlets per wall; and
- d) have outlets placed at
 - i) a minimum distance of 600 mm from the corner of the room; and
 - ii) a maximum distance of 2080 mm between each outlet.

Notes:

- 1) Electrical outlet spacing requirements are intended to permit use from the bed.
- 2) Consider reach ranges within 600 mm when measured from the edge of the bed to an outlet or switch.
- 3) Consider providing an outlet on the ceiling to allow for the installation of a future lift. Outlets placed below (i.e., underneath) the bed will be helpful to accommodate electrically adjustable beds or lifts.

5.11.6 Outlet connections

At least one outlet connection for computer network and communications purposes shall be provided

- a) at a height between 400 and 1100 mm above floor level;
- b) a maximum 600 mm horizontally from the bed edge; and
- c) in a location where access is not impeded by furniture.

5.12 Laundry

5.12.1 General

At least one laundry room or area shall comply with the provisions of Clause [5.12](#).

5.12.2 Area allowances

The laundry room shall be served by an accessible path of travel in accordance with Clause [4.4.1](#).

Notes:

- 1) Laundry rooms are preferably situated near a bedroom to avoid fatigue and for user convenience.
- 2) Laundry rooms can benefit from a turning circle in accordance with Clause [4.4.2](#) b).

5.12.3 Features and appliances

Features and appliances within the laundry room shall be served by clear floor spaces in accordance with Clause [4.4](#).

5.12.4 Doors

Where served by a door, laundry room doors shall comply with Clause [5.7](#).

5.12.5 Floor

The laundry floor shall

- a) be luminance (colour) contrasted from the surrounding walls, features, and appliances; and
- b) where provided, have a one-way slope of not more than 2% to allow for drainage.

5.12.6 Illumination

Laundry illumination shall comply with Clause [4.8](#).

5.12.7 Sink

Where provided, a sink within the laundry room or area shall

- a) comply with Clause [4.4.2](#) a);

- b) meet the counter or rim height (whichever is higher) and knee and toe clearances addressed in Clause [4.4.3](#);
- c) have faucets
 - i) that comply with Clause [4.5](#); and
 - ii) be protected with a mixing valve that limits the water temperature to a maximum of 49 °C; and
- d) have a rear offset drain that is
 - i) insulated;
 - ii) fully protected; or
 - iii) otherwise configured to protect against contact.

Note: Faucets can be installed at the side of the basin for ease of use and shorter reach ranges.

5.12.8 Washer and dryer

The washer and dryer shall

- a) have front-mounted controls that comply with Clause [4.5](#);
- b) be installed side-by-side, not stacked; and
- c) have front-mounted doors that open away from each other (see Figure [37](#)).

Note: There are accessible washing machines and dryers that come with a number of additional helpful features that can allow them to be connected to electronic personal assistants or operated by audio controls. Having appliances that are compatible with smart devices can increase access for many users.

Figure 37
Washer and dryer
(See Clause [5.12.8.](#))

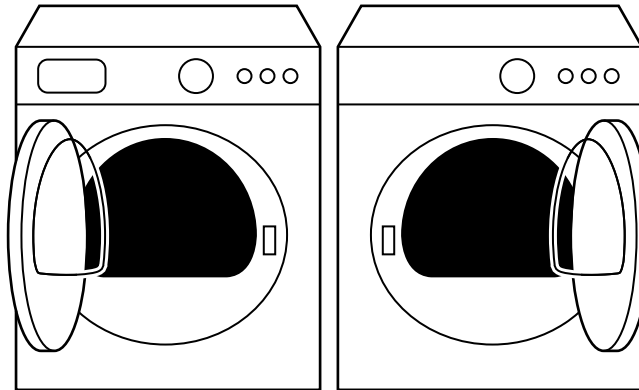

This figure displays a washer and a dryer that are positioned so that the doors open away from each other.

5.12.9 Folding surface

Where provided, a laundry folding surface shall

- a) be at least 820 mm wide by 600 mm deep;
- b) have a surface height, knee, and toe clearance in accordance with Clause [4.4.3](#);
- c) have no 90° edges;
- d) have no sharp or abrasive surfaces under it; and
- e) have an outlet that is not more than 150 mm from the front or side edge.

Note: It is recommended that the edges of the folding surface be bullnose or rounded.

5.12.10 Storage

Where provided, storage shall

- a) comply with Clause [4.4](#); and
- b) include shelving at least 300 mm deep and located between

400 mm and 1100 mm above the finished floor (see Figure [38](#)).

Notes:

- 1) Shelving should be at least 600 mm wide.
- 2) Where overhead shelving is provided, it should be able to drop down either manually or through automation.
- 3) Consider adding hooks in the laundry area for hanging.

5.12.11 Ironing board

Where provided, a built-in ironing board shall comply with Clauses [4.4](#) and [5.12.9](#).

Note: It is recommended that the edges of the ironing board be bullnose or rounded.

5.13 Closets

Where closets are provided (including within bedrooms), they shall

- a) have lighting within them; and
- b) have at least one shelf or hanging rod
 - i) installed not more than 1100 mm above finished floor; or
 - ii) be able to be dropped down either manually or automated (see Figure [38](#)).

Notes:

- 1) An additional clothes rod installed between 1100 mm and 1400 mm above finished floor would accommodate longer garments.
- 2) Some people might prefer closets without doors.
- 3) Consider using mechanisms such as soft-close drawers or doors, and shelves that can be lowered with a pull or electronically.
- 4) Sufficient storage space should be provided for aids such as shower chairs, walkers, transfer benches, commode chairs, and wheeled mobility devices.

Figure 38
Closet storage
 (See Clauses [5.12.10](#) and [5.13.](#))

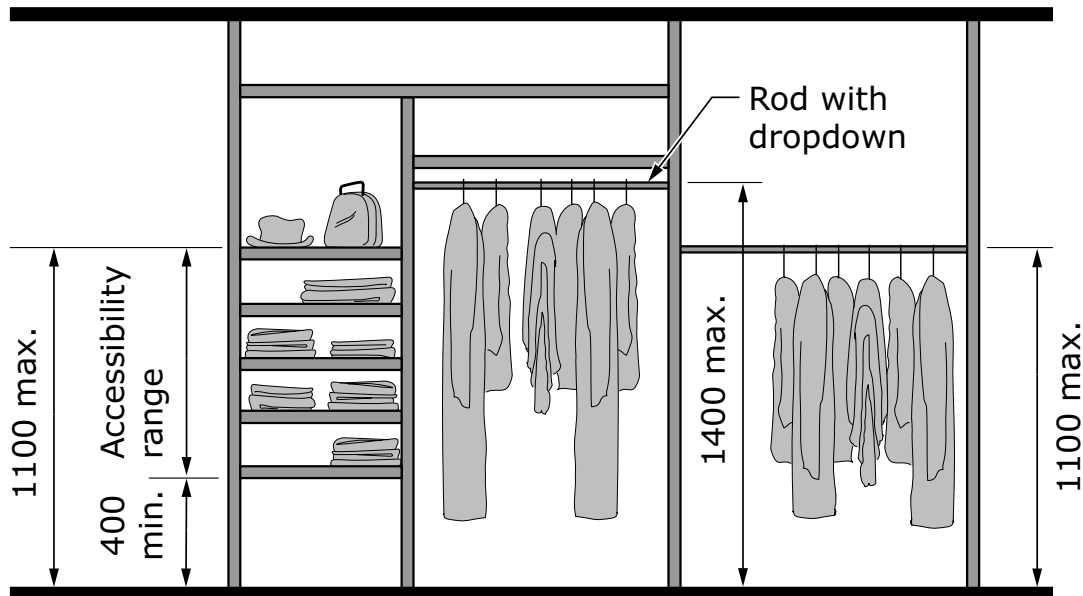

This figure depicts a closet showing the height of shelves and hanging rods. It indicates the accessibility range between 400 mm and 1100 mm for positioning shelves and a maximum 1100 mm height for hanging rods. A hanging rod with dropdown is shown positioned 1400 mm above the ground.

Note: All dimensions are in mm.

5.14 Home automation

Where provided, the surface-mounted user interface of home automation systems shall comply with Clauses [4.4](#) and [4.5](#).

Notes:

- 1) Elements of home automation systems typically include a control system (i.e., a computer, security system, telephone, etc.), the device being operated (e.g., lights, furnace, appliances), and the interface, or link between the user and the device. An interface can be a button, a keypad, a motion sensor, a wireless tablet, or a smartphone. Consideration of the overall control system

(central or application-based) is essential to the overall operation of the home automation system.

- 2) Home automation features can include but are not limited to doorbells, mechanically (i.e., remote-controlled) operated windows, door openers, motion sensor lights, telephone jacks and electrical outlets for computers located in various parts of the home, extra outlets to accommodate changing technology, and security systems for fire and theft.
- 3) It is recommended that home automation services also be hardwired in case of non-reliable internet services, or have an alternative means of remaining operative when offline.
- 4) Some home automation equipment (e.g., medical devices, security systems) might not have back-up power built in and therefore can benefit from a back-up generator or a back-up power supply (i.e., uninterruptible power supply, also known as UPS). Where a back-up power system is provided, consider the area allowances in Clause [4.4](#) and operating control provisions in Clause [4.5](#).

5.15 Service rooms and spaces

Where a service room (i.e., a room dedicated to garbage disposal, mailboxes, or mechanical or electrical equipment) is provided, it shall

- a) be served by an accessible path of travel in accordance with Clause [4.4.1](#);
- b) be served by a clear floor space in accordance with Clause [4.4.2](#) a); and
- c) have its equipment controls located in accordance with Clause [4.5](#), with the exception of items that require servicing by professionals.

Notes:

- 1) In a multi-level dwelling, having the equipment room on the main level for ease of access is ideal.
- 2) Ideally, home environment systems would permit any user to access and operate them (i.e., permit the changing of furnace or

humidifier filters, allow ease of access to shut-off switches for furnaces and hot water heaters, etc.).

5.16 Alert and signal devices

Emergency alert and signal devices shall be equipped to provide both visual and audible signals.

Notes:

- 1) Examples of emergency alert and signal devices that can be used within dwellings include
 - a) smoke detectors;
 - b) carbon monoxide detectors;
 - c) heat detectors;
 - d) emergency illumination (lighting); and
 - e) flood detection systems (where provided).
- 2) In situations where an individual has low or no hearing, additional devices are recommended in all rooms and spaces. Alternatively, there are hardwired devices that are compatible with vibration alert systems.
- 3) Dual sensor fire and smoke alarms can provide the earliest warning signals.

